

INSTALLATION MANUAL



PREMIUM PREHEAT 250 , 300, 500

Air-air heat recovery ventilation heat pump

TABLE OF CONTENT

Installation	3
Set-up	4
Duct connection	5
Duct system.....	5
Condensation drain.....	6
Insulation of ducts in cold attics.....	6
Insulation of ducts in warm rooms.....	7
Electrical connection	7
Starting up the system.....	7
Optimal adjustment of the ventilation system	8
Maintenance of the system	8
Trouble-shooting	10
Electrical diagram - Optima 301	11
Cooling circuit	13

INSTALLATION

• IMPORTANT • IMPORTANT • IMPORTANT

When installing a Premium Preheat unit, the instructions below must be followed:

Check that the unit is level.

Install airtight water traps in a frost-free location to compensate the pressure of the valve.

The height of the water traps must be at least 100 mm.

Ensure that the condensation pipe is inclined all the way from the unit to the drain.

Pour some water into the condensation tray of the unit to ensure that it flows out freely.

If the water trap is fitted in a place where there is a risk that the temperature drops below 0°C, then an electric heating element with a thermostat protects it against freezing by turning on when the temperature drops below +2°C.

Adjustment of supply air and extract air volumes must be made before the ventilation system may be taken into use. It is important that there is a balance between the supply air and extract air volumes.

Closing the ceiling valves etc. is recommended, until the ventilation system is started up.

METRO THERM A/S may not be held liable for any consequential damages, which have nothing to do with the Genvex unit.

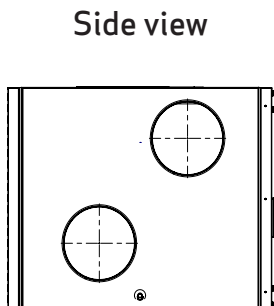
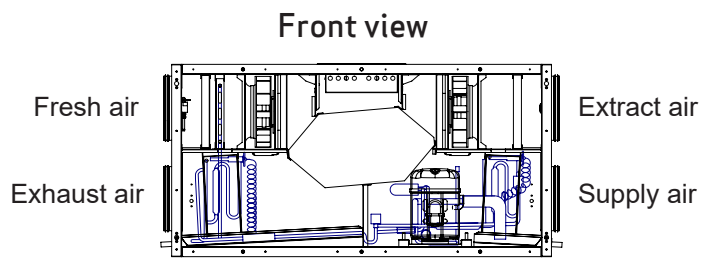

Set-up

Premium Preheat is a reversible heat pump that can be supplied with the supply air in the right-hand side (as shown) or in the left-hand side. The electrical box is located on the top of the unit. The electrical box is located on the top of the unit.

The unit has 2 condensation drains, both of which must be connected to a suitable drain.

The unit must be placed on a solid surface, so that vibrations from the unit are not transmitted in ceiling and walls.

The condensation drains must be supplied with the necessary water traps, and condensation hoses/pipes are to be placed frost-free and led to the inside drain.

During the winter months the unit can give off 5-8 litres of condensation per day.

In order for service and maintenance of the unit to be carried out, there must be at least 600 mm clearance in front of the unit, as well as a solid surface, such as a walkway. If the unit is in an attic, there must be free access from the door or hatch.

It is highly advisable to place the unit under the roof or in the attic.

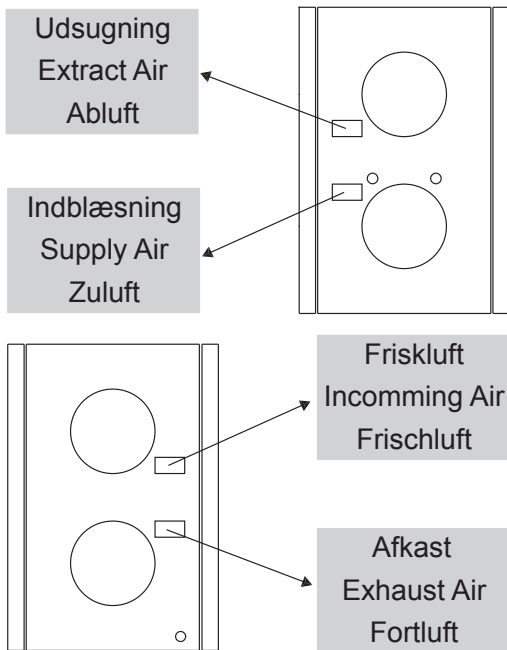

Duct connection

At each duct connection there is a yellow sticker indicating which ventilation duct is to be connected to which bushing.

Supply air

The duct system from the unit to the rooms.

Extract air

The duct system from the wet rooms to the unit.

Fresh air

The duct system from the fresh air roof cowls/external grills to the unit.

Exhaust air

The duct system from the unit to the exhaust air roof cowls/external grills.

Duct system

It is recommended that the ventilation duct system is made of spiral ducts with rubber ring seal fittings so as to provide a tight and durable duct system.

There are also other duct systems: Flat metal ducts and plastic duct systems.

To obtain a satisfactorily low noise level from the unit, silencers must always be mounted on the supply air and extract air ducts between the unit and the first supply air and extract air valves. A silencer on the exhaust air duct is also recommended.

To prevent the transmission of sound from one room to another, we recommend always installing a silencer between the two rooms.

It is recommended that the air speeds in the ducts be dimensioned low enough so that there is no noise from the supply air and extract air valves.

When positioning the fresh air and exhaust air roof cowls/grills, make sure that the two air flows do not intercept causing exhaust air to be drawn in again. Minimum spacing: 3 m.

It is recommended that the fresh air grills are placed on the north or east side of the house to ensure optimum comfort.

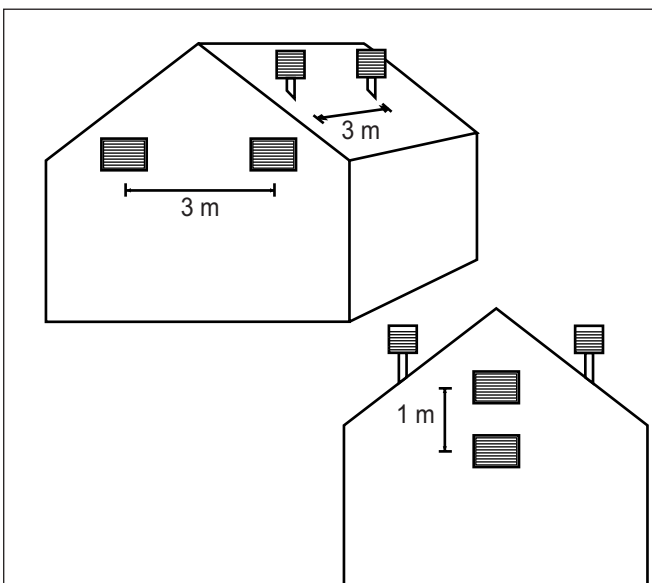

Condensation drain

The units can give off 5-8 litres of condensation in a day. Therefore, it is important that the condensation drains have been carried out correctly. The condensation drain pipes must be mounted with the necessary gradient from the condensation connections on the unit and to the internal drain.

On each condensation drain pipe a water trap must be fitted, because there is negative pressure in the chamber where the condensation tray is installed. If the unit is mounted in a cold attic, the condensation drain pipes must be insulated so that the condensation in the pipes does not freeze up.

However, it is recommended that the water traps are installed in a heated space to ensure that the water in the water traps does not freeze.

If installation problems make it impossible to secure the condensate drain pipe from freezing using insulation, it will be necessary to mount a thermostat-controlled heating coil around the condensate drain pipes.

In connection with checking and replacing filters, it is recommended that the water traps are checked and then filled with water if necessary.

Insulation of ducts in cold attics

In order to benefit from the unit's high heat recovery rate, it is necessary that the ducts are insulated properly.

We recommend the following:

Supply air and extract air ducts

In order to minimise the loss of heat from the duct system in cold attics, the supply air and extract air ducts must be insulated with a minimum of 100 mm insulation. If insulation type A is chosen, it is recommended that insulating is done with two layers of 50 mm lamella mat finished off with paper or foil on the outside and that the joints between the two insulation layers are staggered. If the ducts are positioned on the rafter foots, then type B can be used. The insulation must always be tightly wrapped around the ducts, especially on fresh air and exhaust air ducts in cold rooms.

Fresh air and exhaust air ducts

It is recommended that fresh air and escape air ducts are insulated with a minimum of 50 mm insulation. The fresh air duct is insulated to prevent warm air in the attic heating up the fresh air during the summer. Make sure to seal tightly, especially where the ducts are led through the roof or out through gables in order to avoid condensation damage.

Contact your local supplier for instructions about national guidelines concerning insulation.

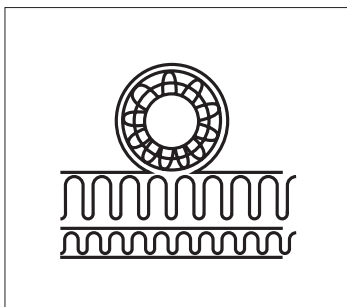
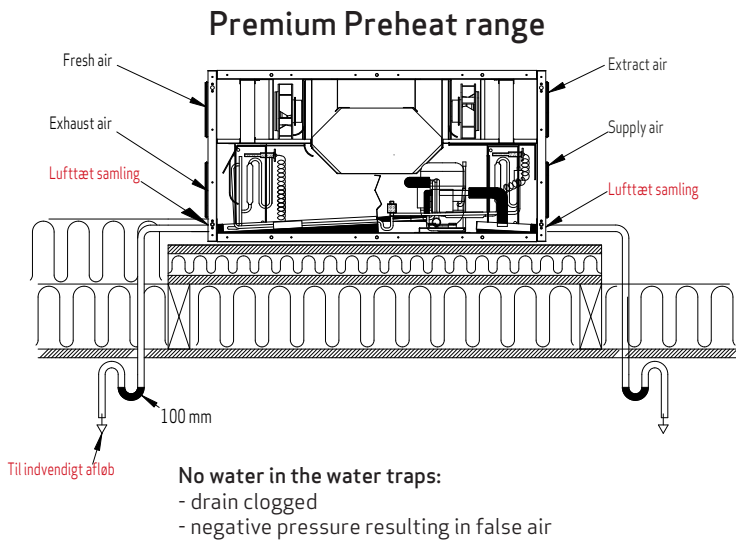

Duct insulation, alt. A

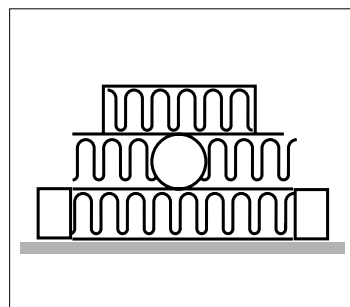

Duct insulation, alt. B

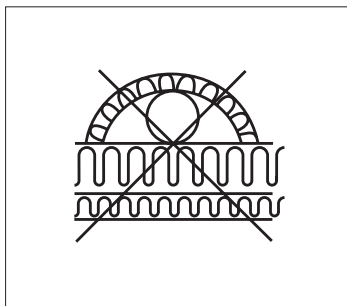

Faulty duct insulation

Insulation of ducts in warm rooms

We recommend the following:

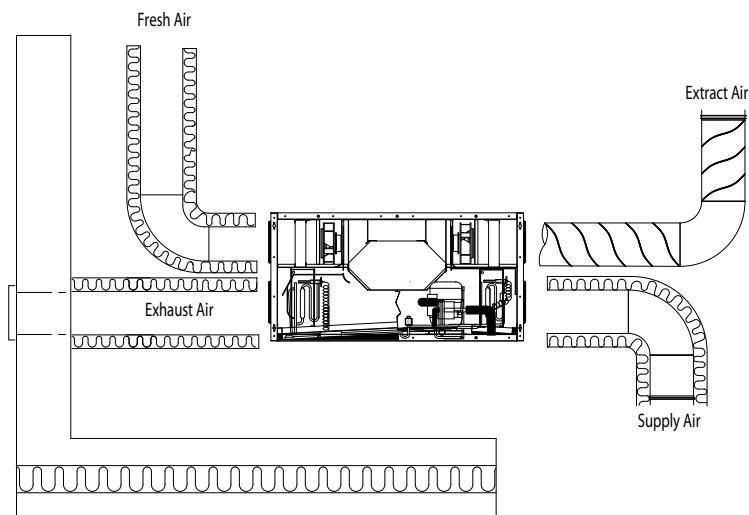

Supply air and extract air ducts:

Supply air ducts, which lead to heated rooms in the home, must be insulated, since condensation can form on the cold supply air ducts when cooling. For this purpose, diffusion tight material must be used, for example a 19 mm Kaiflex mat, self-adhesive, or 50 mm mineral wool finished with aluminium foil on the outside.

Extract air ducts installed in heated rooms in the house do not need to be insulated.

Fresh air and exhaust air ducts:

In warm attics and heated rooms in the house, fresh air and exhaust air ducts must be insulated with a minimum of 50 mm of insulation.

In addition, the insulation must be covered on the outside with plastic or aluminium foil to avoid condensation in the insulation.

Contact your local supplier for instructions about national guidelines concerning insulation.



Electrical connection

The electrical connection must be performed by a certified electrician in accordance with EN 60364, refer to the electrical diagram.

The cable between the unit and control panel must be a 4-wire min. 0.25 mm² cable with a maximum length of 50 m.

Starting up the system

To achieve optimum operation of the system it must be adjusted with air measuring equipment.

If you wish to start up the unit before adjustment, the following must be done before the system is started:

1. Make sure that the unit has been correctly installed and that all ducts have been insulated in accordance with the national regulations.
2. Make sure that the covers can be opened so that it is possible to perform service and maintenance on the unit.
3. Make sure that the filters are clean (they can be dirty after installation).
4. Make sure that the condensation drains are correctly fitted with water traps and protected against frost.
Pour 1 litre of water into the condensation trays and see if it runs freely through the condensation drain pipes.
5. Adjust all the supply valves so that the valve closest to the unit is opened three turns from closed position, while the furthest is open eight turns from closed position. Open the valves in between 4-7 turns depending on how far they are from the unit.

The unit can now be started up and run until adjustment with air measurement equipment has been carried out.

Optimal adjustment of the ventilation system

Use air measuring equipment

Before adjustment is conducted, make sure that the 5 points in the section „Starting the system“ have been carried out. Then start up the unit.

Adjust the system to basic ventilation (= fan step 2). To achieve maximum energy savings, adjust the main air volumes first to the desired air volume via the display from a PC.

Then adjust the supply air and extract air valves using the air measuring equipment. When adjusting the valves, remember that they will be locked, and that any splitter place on the supply air valves must be turned so that the air blows in the right direction. Then check the main air volumes again, and fine-tune the main air volumes with the fresh air and escape air dampers. Remember to close the dampers after adjusting.

Maintenance of the system

Filters

When the filter timer reaches the set value for filter change, "Alarm!" will show in the screen saver and "Chg. filter" will flash. This means that it is time to clean/change the filters.

Switch the unit off on the switch on the control panel or the switch on the electrical panel. Open the front doors and remove the filters. When the filters have been cleaned/replaced, close the front doors and reset the filter alarm by holding down the button below the filter symbol, until "Alarm!"; "Chg. Filter" and the exclamation mark disappears in the filter symbol. The unit reverts to normal operation.

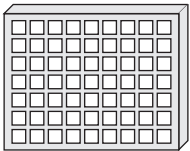

M4 = Standard filter (Coarse filter class M4)

F5 = Fine filter (Fine filter class F5)

F7 = Pollen filter (Fine filter class F7)



Danger of cutting on sharp blades. The blades must not be damaged.



It is not recommended to vacuum or use air pressure on the filter, since the degree of filtering will be decreased.



Remember: The system may not be opened before power has been disconnected from the system.

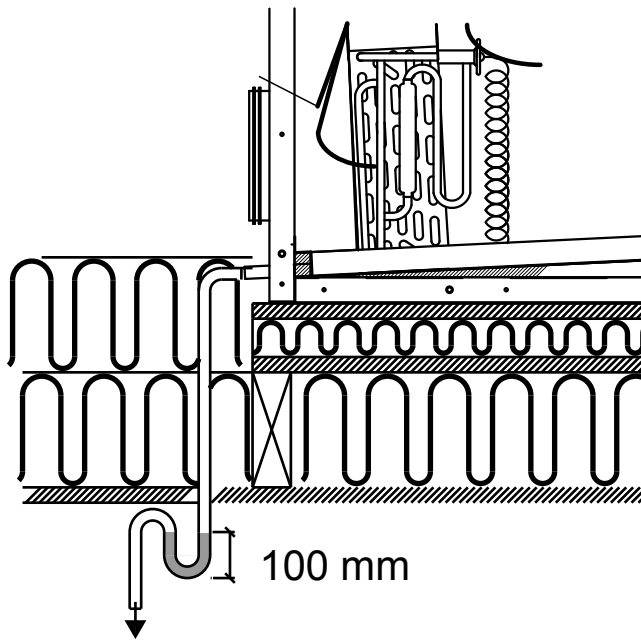

Condensation drain

When changing the filter in August/September before the outside temperature falls to 5°C, check that the condensation drain is not blocked with dirt and make sure that there is water in the water trap. Pour 1 litre of water into the condensation tray and make sure it runs off freely. If the condensation drain does not work, this could lead to water damage in the home.

Heat exchanger

Inspect the heat exchanger every year. If it is dirty, remove it and:

- **Alu-exchanger:** Wash in lukewarm soapy water and rinse using a hand shower if necessary.
- **Plastic exchanger:** No cleaning with fluids (including water); only careful dust removal from air intake surfaces with a household vacuum cleaner.

Fans

Inspect the two fan wheels for dirt each year. If they are dirty, they can be washed using a brush, bottle cleaner, etc.

Supply air and extract air valves

Clean the valves by wiping with a dry cloth. Be careful that the valves do not turn, so that the air volume changes.

Service

If you are not able to maintain your system, you can make a service agreement with the Genvex Service Department. If any faults on the system arise, please contact the Genvex Service Department.

TROUBLE-SHOOTING

System stopped

Error:

- Fuse in main board has blown, no power to unit.
- One of the fuses on the circuit board of the unit is blown.
- Loose wire, no power to unit.
- Loose wire between unit and control panel.
- Faulty or incorrectly set week program.
- High pressure switch is disengaged.
- Filter timer has switched the system off.

Condensation is running out of the unit

Error:

- Condensation drain clogged with dirt.
- No water in the water traps.
- Clogged condensation drains due to frost. The drain is not sufficiently protected against frost.
- Water trap has not been installed correctly.

No supply air

Error:

- Faulty supply air fan
- Clogged supply air filter
- Clogged fresh air grill due to dirt and leaves during the fall and snow and ice during the winter.
- Fuse on the circuit board is blown.
- The unit is in defrost mode (supply air fan stops)
- Incorrect value set in service menu item 20

No extract air

Error:

- Faulty extract air fan
- Clogged extract air filter.
- Fuse on the circuit board is blown.

Cold supply air

Error:

- Clogged heat changer.
- Faulty extract air fan.
- Clogged extract air filter.
- Electrical reheater is disconnected at the over heating thermostat (only units with electrical reheater installed).
- Air in the heating pipes, faulty thermostat/motor valve, incorrect setting of control panel.

ELECTRICAL DIAGRAM - OPTIMA 301

Optima 301

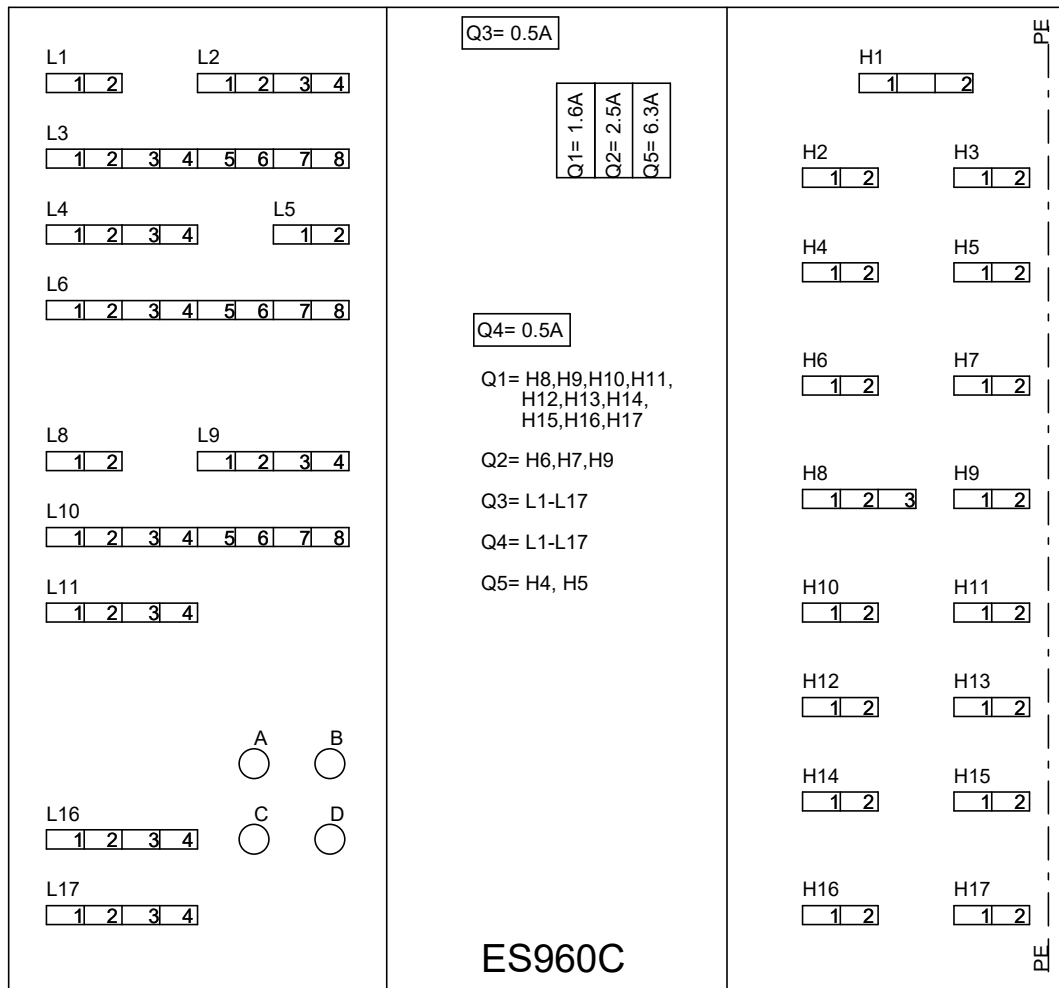

A = LED Flash - Power on
B = LED Flash - Communication to Optima Display

L1 = Potential free input for optional:
Humidistat, Extractor hood ,CO2
L2 = Optima Display
L3 = Sensors T1,T3,T4,T7
L4 = Not in use
L5 = Not in use
L6 = Sensors T5,T6,T8,T9
L8 = External stop
L9 = Fan RPM
L10 = Not in use
L11 = 0-10V Motorvalve Reheating
0-10V Belimo LM230ASR bypass
L16 = Not in use
L17 = 0-10V extract air fan and
0-10V supply air fan

H1 = Mains connection 230 VAC
H2 = (R2) Electric Reheater Step A 230VAC
H3 = (R3) Electric Preheater 230VAC
H2,H3 = Max. load total 1800W
H4 = (R1) High pressure switch
H5 = (R1) Compressor230VAC
H6 = (R10) Motorvalve Reheating,
Belimo LM230ASR 230VAC
H7 = (R10) Fan, extract air 230VAC
H8 = (R12) Not in use
H9 = (R10) Fan, supply air 230VAC
H10 = (R4) Soleniod valve MA4 Defrost 230VAC
H11 = (R7) Extra relay 230VAC
H12 = (R5) Electric Reheater Step B 230VAC
H13 = (R5) Electric Reheater Step B 230VAC
H14 = (R6) Electric Reheater Step C 230VAC
H15 = (R6) Electric Reheater Step C 230VAC
H16 = (R8) Soleniod valve MA7 Cooling 230VAC
H17 = (R9) AUX relay 230VAC

JRS
06-02-2024
Version 1,3

Potential free input for optional: Humidistat, Extractor hood, CO2

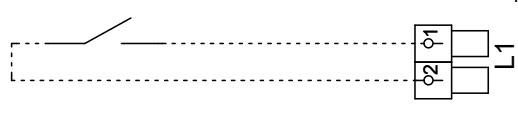

Optima Design

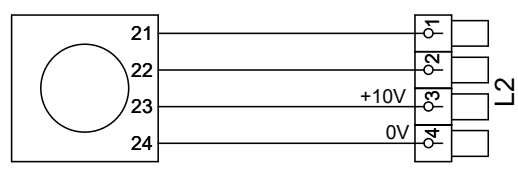

Sensor, supply air

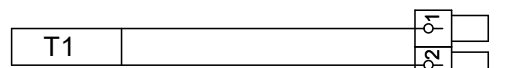

Sensor, fresh air

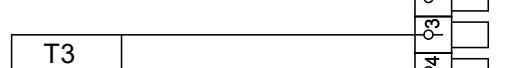

Sensor, exhaust air

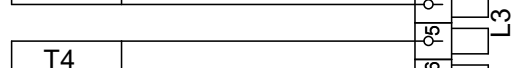

Sensor, extract air

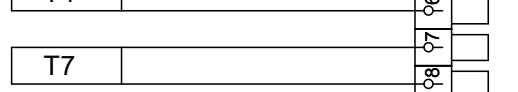

Sensor before evaporator

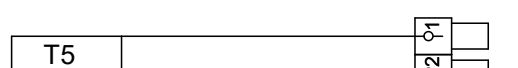

Sensor, evaporator

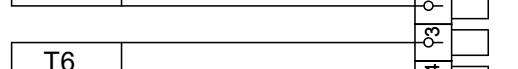

Sensor Frost



Sensor Option

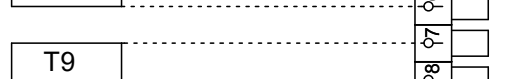

External stop



Control signal Motorvalve Reheating

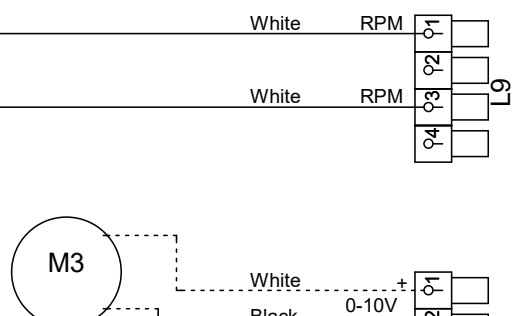

Belimo LM230ASR Bypass

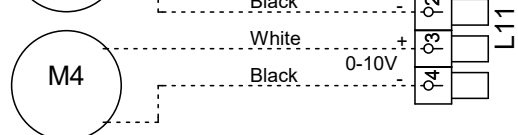

EC fan Extract air

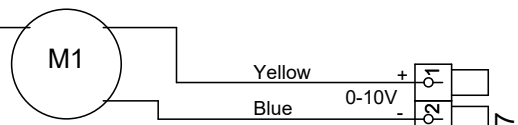

EC fan Supply air

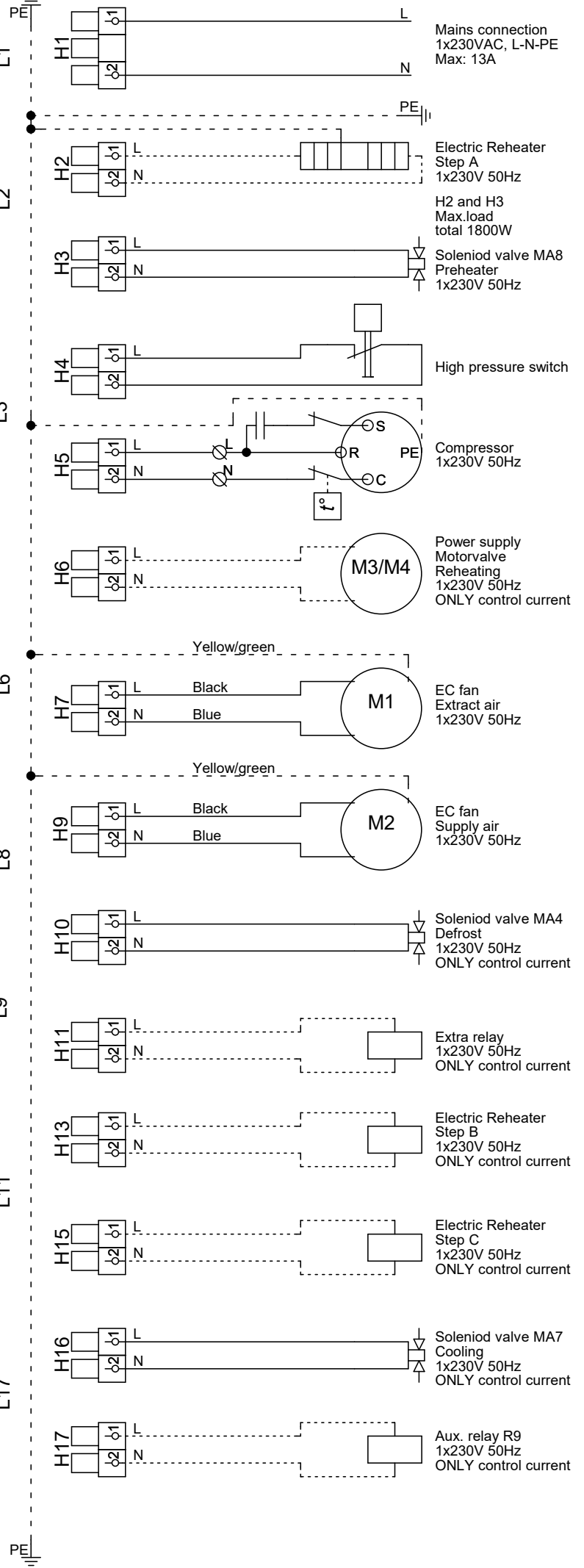
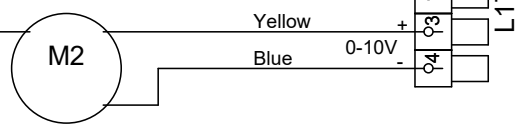

COOLING CIRCUIT

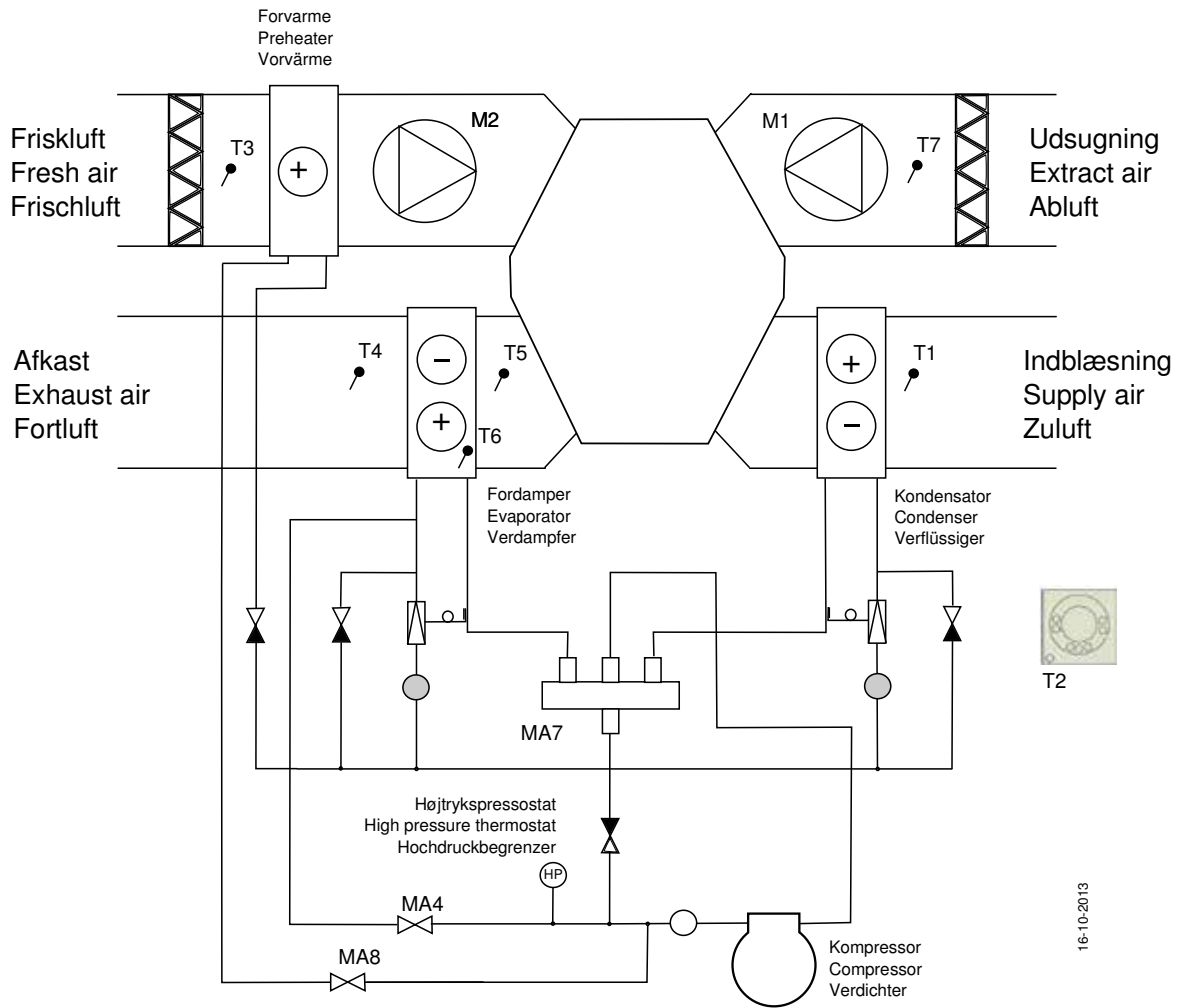

16-10-2013

THE AIR WE BREATHE

All
Genvex
systems are
rated with
energy label
A

As of January 1, 2025, METRO THERM has merged with KVM-Genvex A/S into a single entity under the shared name METRO THERM A/S.

The three well-known brands – METRO THERM, Genvex and KVM-Conheat – will continue as before, as is also the case for our production and administration sites, which will continue unchanged at our facilities in Helsingør and Haderslev.

The merger is a natural progression of our strong collaboration and a strategic decision to strengthen our position as one of Northern Europe's leading suppliers of heating, hot water, and ventilation solutions.



Genvex - The original Danish Ventilation System

Genvex is a genuine Danish original. We invented the ventilation system more than 40 years ago, and we are still ahead of the pack when it comes to development and production of the strongest and most durable ventilation system.

Our unit is working in thousands of homes providing fresh clean air – free of pollen, dust and harmful particles. This helps to strengthen the health of the house and to make the indoor environment healthy and comfortable for lots of families. At the same time, our system is an important element when it comes to saving energy in homes and in society as a whole – in fact you can recover up to 95% of the heat energy with a Genvex system.



08:241-2602