

INSTALLATION INSTRUCTIONS



ECO 300/ECO 300 XL

Mechanical ventilation with passive heat recovery

TABLE OF CONTENTS

Safety information	3
Functional description	3
Installation	4
Dimensional sketch	5
Duct connection.....	7
Duct system	7
Condensation drain.....	8
Insulation of ducts in cold attics	9
Insulation of ducts in warm rooms.....	10
Post-heating of the supply air	10
Preheating of outdoor air.....	10
Electrical installation.....	11
Control and calibration of the system.....	11
Optimal initial calibration of the system.....	12
System maintenance.....	12
Access to internal parts.....	14
Recommended maintenance intervals	15
Spare parts	16
Troubleshooting	17
System not running.....	17
No supply air	17
No exhaust air	17
Cold supply air	17
Alerts	17
Electrical diagram - Optima 270	18
Declaration of conformity	19

SAFETY INFORMATION

This manual also describes installation and service work to be performed by a professional.

This device can be used by children aged 8 and over and by people with reduced physical, sensory and mental capabilities or lack of experience and knowledge, as long as they are supervised or have been instructed in the safe use of the unit and understand the dangers involved. Children must not play with the device. Children must not clean or maintain the appliance without supervision.

Subject to design changes.

Labelling

The CE mark represents METRO THERM's assurance that the product complies with all regulations laid down for the product in accordance with relevant EU directives. The CE mark is mandatory for most products sold in the EU, irrespective of where they are made.

FUNCTIONAL DESCRIPTION

ECO 300/ECO 300 XL is a horizontally mounted ventilation system for ventilation in homes.

The system is equipped with a highly efficient counter-flow heat exchanger, which recovers the heat in the exhaust air from the home and preheats the fresh supply air.

ECO 300/ECO 300 XL can be configured as either right- or left-facing depending on the installation conditions.

An integrated preheater can be selected for the system to ensure that balanced air volumes can be maintained – even with very cold outdoor temperatures.

You can also choose an integrated water level switch, which ensures that the system stops and an alarm is shown on the display if problems with the condensate drain occur (e.g., clogged floor drain).

ECO 300/ECO 300 XL has been designed for installation outside the thermal envelope and has low heat loss due to a very high thermal insulation performance. The system is not intended for installation outside of buildings.

INSTALLATION

IMPORTANT:

Follow these instructions when installing the ECO 300/ECO 300 XL:

- 1) The system must be installed to allow the condensation water to drain freely.
- 2) An airtight drain trap must be installed in a frost-free location to compensate for fan pressure.
- 3) The drain trap must be a minimum of 50 mm in height.
- 4) Ensure the fall in the drain extends all the way to the drain outlet.
- 5) Pour 1 litre of water into the condensate tray of the unit to check that it drains correctly. Make sure the drain trap is filled with water every year before beginning to use the unit.
- 6) If the drain trap is installed in an area where temperatures can drop below 0°C, then the drain trap must be protected against freezing by a thermostat and an electric heating element that turns on when the temperature drops below +2°C.
- 7) The airflow volume for the supply air and exhaust air must be adjusted before using the unit. It is important to maintain an air balance inside the house.
- 8) We recommend closing the ceiling vents, etc., until the system has been started up and adjusted.

METRO THERM A/S always recommends careful planning of the installation space for your Genvex product in relation to the location of living spaces. As this is a technical product that contains fans and/or a heat pump, in rare cases, and in combination with inappropriate installation conditions, it may cause unsatisfactory noise or vibration nuisances. As a rule, we always recommend installing the technical system so that it is not located in the immediate vicinity of a bedroom. Furthermore, when securing the Genvex system to the building structure, it is recommended attaching it to a heavy structural component such as concrete. It should also be ensured that no sound or vibrations can be transmitted through materials in contact with the technical system. If there is a risk of propagation of noise and vibrations, further installation of vibration-damping material and sound-damping of installation rooms are recommended.

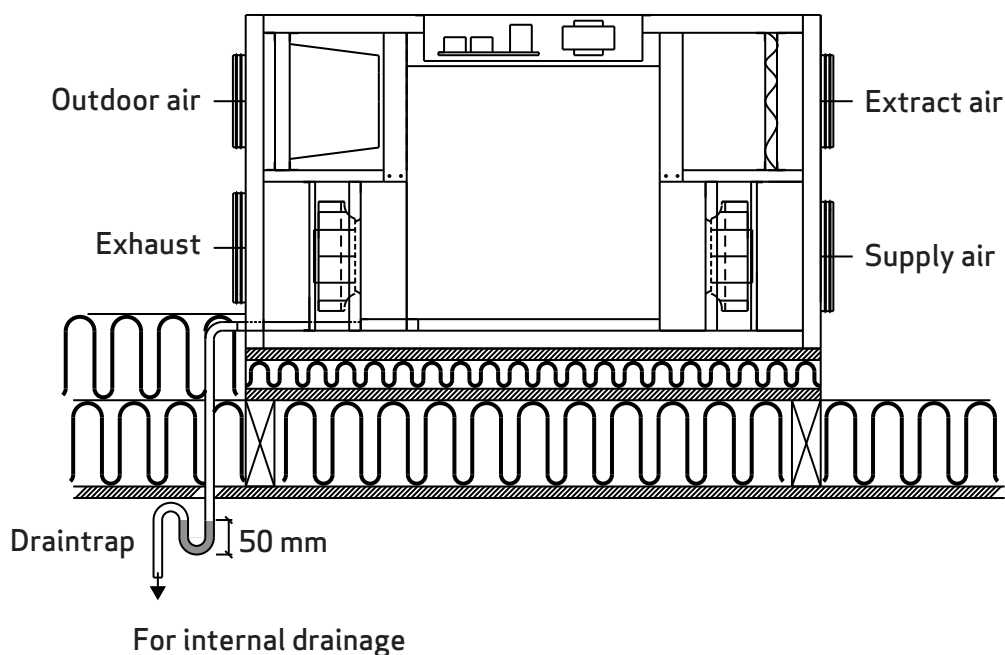

Dimensional sketch in mm.

1. Outdoor air
2. Exhaust air
3. Extract air
4. Supply air
5. Heat exchanger
6. Supply air fan
7. Exhaust fan
8. Filter outdoor air
9. Filter exhaust air
10. Condensate drain
11. Electrical connection
12. Bypass

The ECO 300/ECO 300 XL is supplied as either right- or left-facing, as shown in the schematics below. If you want the condensate drain at the opposite end, simply remove the front cover and back panel on the unit, then install the back panel on the front and rotate the unit 180°.

Please note that the internal cable routing is at the front of the system on the ordered model. Therefore, ensure an appropriate distance at the rear cover if the system is rotated relative to the model delivered.

The unit must be placed on a surface so that vibrations from the unit are not transmitted down through the ceiling and walls. The unit can produce up to 8 litres of condensation per day during the winter, so the condensate drain and the requisite drain trap must flow to the internal drain without risk of frost.

To service and maintain the unit, there must be at least 600 mm of clearance in front of the unit and a surface that can be walked on. If the unit is placed in the attic, then there must be free access from the attic hatch to the unit.

Right-facing

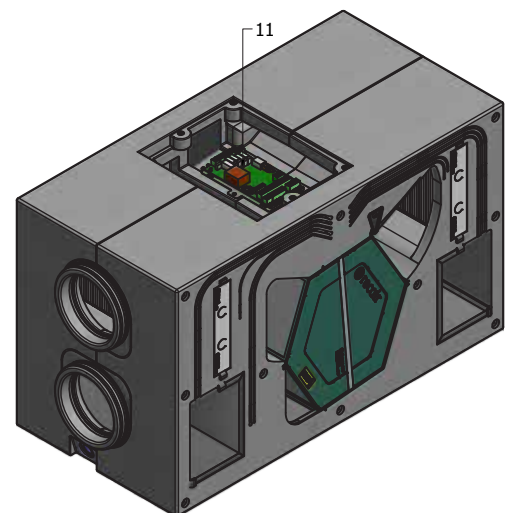
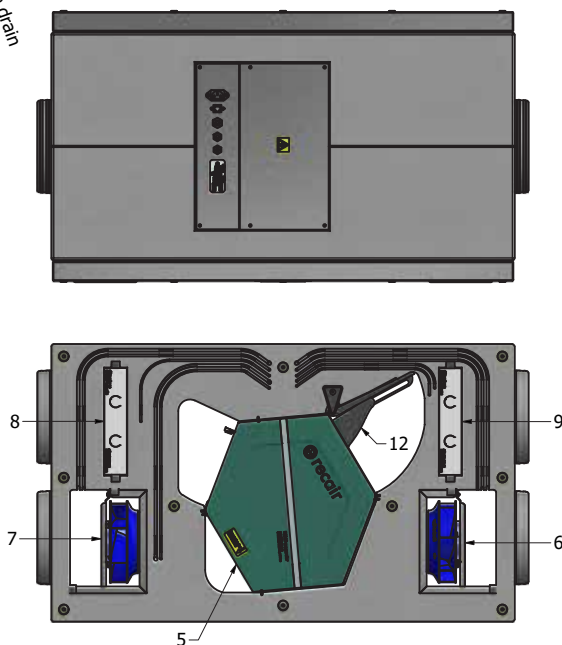
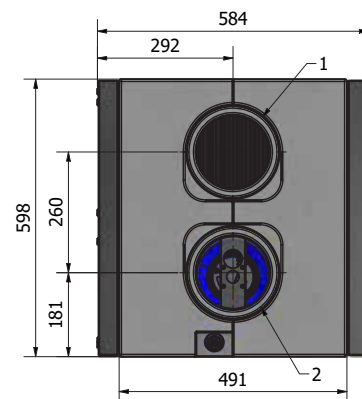
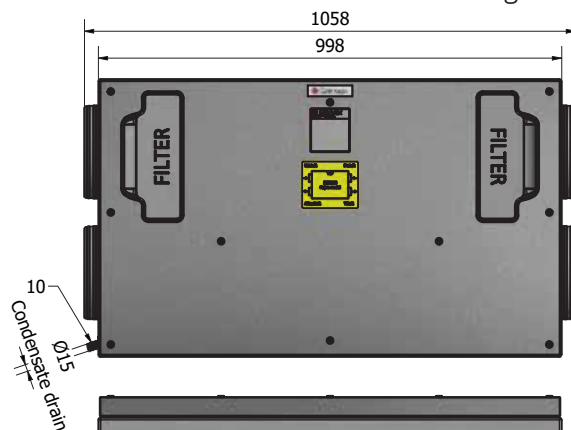
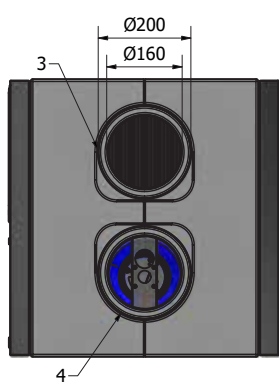

Weight: 33 kg

Left-facing

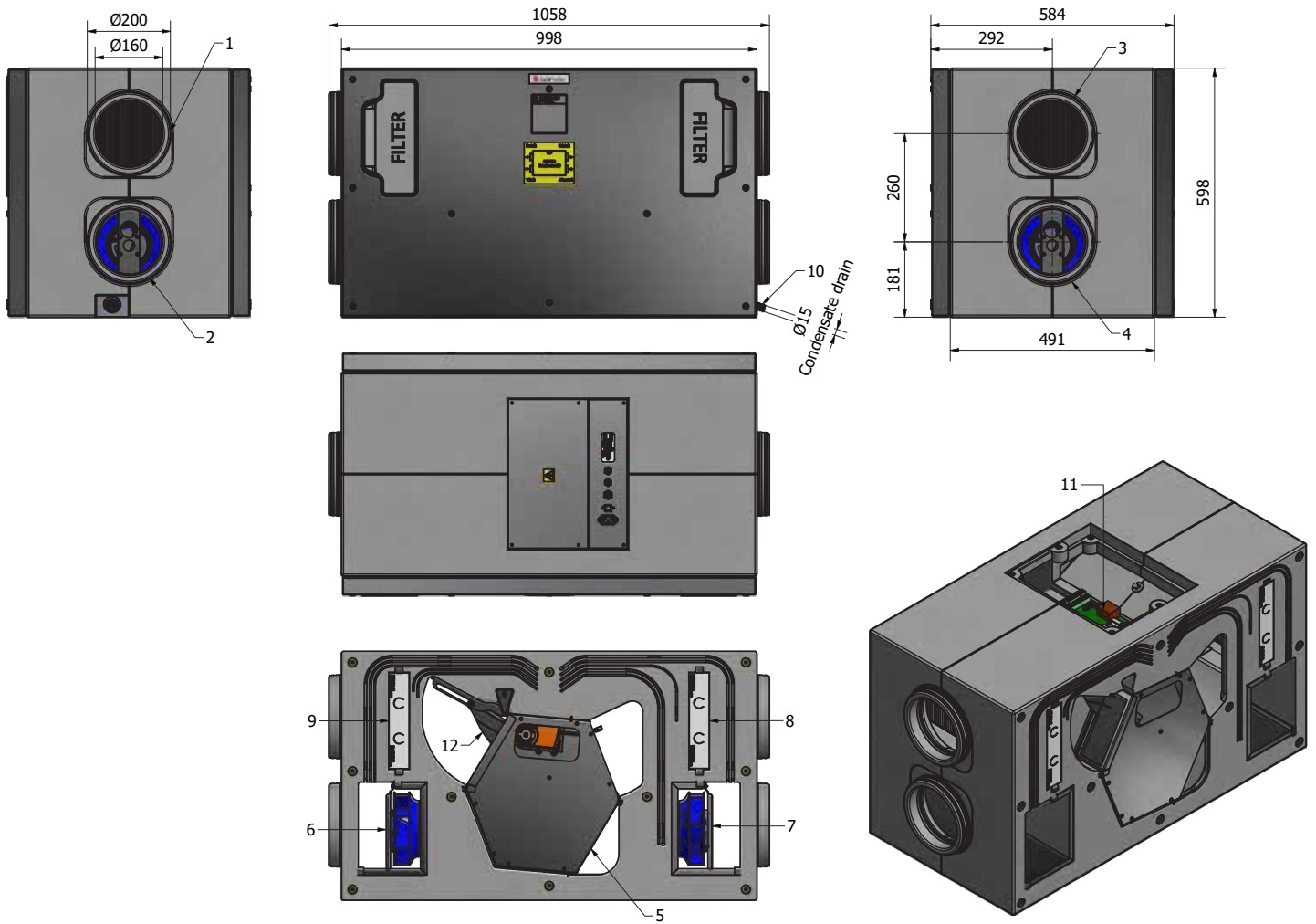

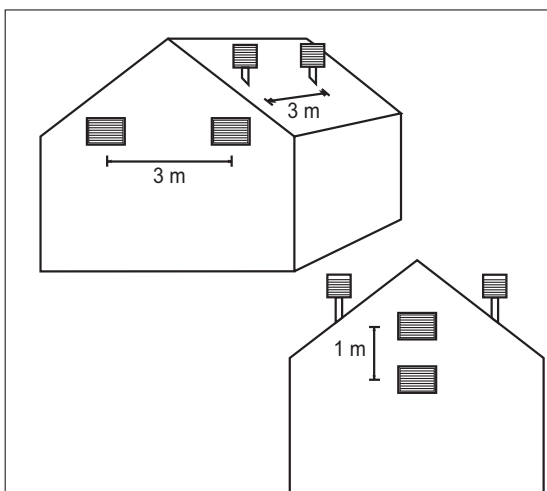
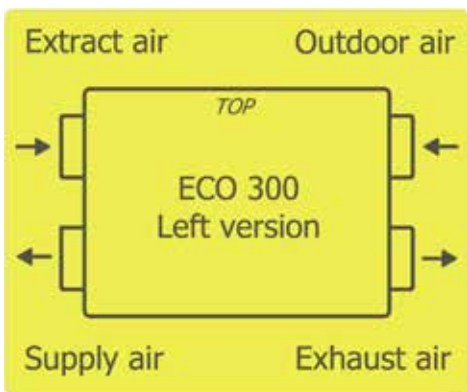
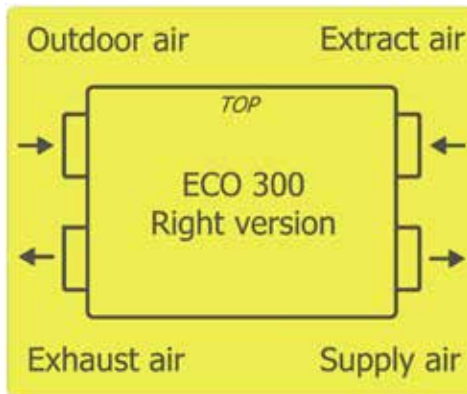

Duct connection

A label on the front cover indicates which ventilation ducts must be connected to the various connecting pipes.

Please note that the designations on the label are not valid if the system is reconfigured from e.g. right to left after delivery.

Connect supply air

Duct system from unit to supply air in living room.

Connect extract air

Duct system from wet rooms to the unit.

Outdoor air connected

Duct system from outdoor air intake hood/outdoor air intake grille from outdoors or from the ground exchanger to unit.

Exhaust is connected

Duct system from unit to exhaust hood/exhaust grille to open air.

Duct system

It is recommended that the duct system is constructed using spiral-folded pipes and fittings with rubber ring seals to achieve a tight and long-lasting duct system.

To achieve a satisfactorily low noise level from the unit, sound locks must always be fitted to the supply and exhaust air duct system between the unit and the first supply and exhaust air fittings.

Air velocities in the ducts should be dimensioned at a sufficiently low rate so that no noise is generated by the supply and extract air fittings.

When placing outdoor air and exhaust air hoods/gratings, care must be taken not to short-circuit the two airflows, thus causing exhaust air to avoid being sucked back in.

It is recommended that gratings be placed on the north or east side of the house for optimal comfort in homes/apartments.

Minimum distance: 3 metres



Tighten the supplied hose nozzle carefully until the O-ring seals against the insert in the threaded connection, and the condensation drain hose can then be connected to the connecting pipe on the hose.

Check that the connecting pipe on the hose has been installed correctly by pouring water into the condensate tray and placing a finger over the outlet from the connecting pipe. Check that no water escapes at the O-ring seal.

Condensation water drain

Condensate drain

The ventilation unit produces up to 8 litres of condensed water per day. It is therefore important to mount the condensate drain correctly. An ordinary Ø15 mm hose can be connected directly to the ventilation unit.

It is important to make a loop on the hose, so that a drain trap with a minimum of 50 mm is formed.

Water column

There must be a drop of 1% from the drain trap and the hose towards the drain. If the unit is installed in a cold environment the condensate drain must be insulated to prevent the condensation water in the pipe from freezing. However, it is recommended that the drain trap is installed in a heated area to ensure that the water inside it does not freeze. If installation problems make it impossible to protect the condensate drain against frost using insulation, then a thermostatically controlled heating wire must be installed around the condensate drain. During operation, the unit experiences internal negative pressure. Therefore, it is necessary to ensure a water column height of at least 50 mm in the drain trap under all conditions.

If the heater is installed in a cold attic, the condensation water drainpipe must be insulated so that the condensation water in the pipe does not freeze.

We also recommend installing the drain trap in a heated room below to ensure that the water in the drain trap does not freeze.

If it is not possible to protect the condensation water drainpipe against freezing by insulating it, then a thermostatically controlled heating element must be installed around the condensation water drainpipe.

When hanging on a wooden wall, a vibration damper is recommended to avoid vibration transmission.

As an alternative to the looped drain trap, a Genvex universal drain trap with hose connection can be used, product no. 063289 (see the photo below).



Genvex universal drain trap

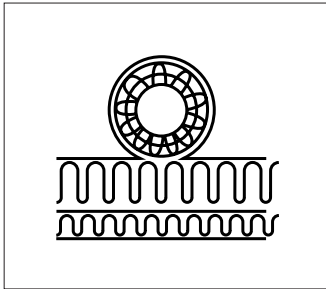

Isolering af kanaler, alt. A

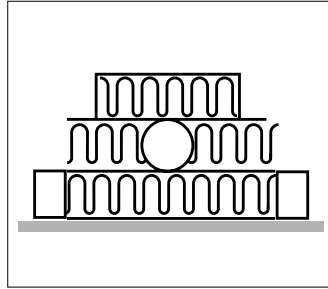

Isolering af kanaler, alt. B

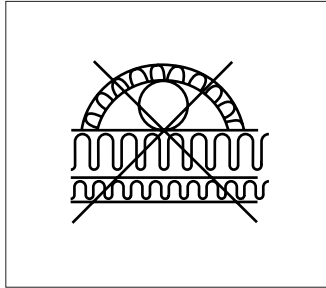

Forkert isolering af kanaler

Insulation of ducts in cold attics

To utilise the full heat recovery capacity of the units, the ducts must be properly insulated.

We recommend the following:

Supply air and extract air ducts

To minimise heat loss from the duct system in cold attics, supply and extract air ducts should be insulated with a minimum of 100 mm insulation. If insulation form alternative (A) is used, it is recommended that the insulation is made of 2 x 50 mm lamella mats with paper or aluminum foil on the outside, and with staggered joints between the 2 insulation layers. If the ducts are laid out on the truss frame, alternative B can be used. Insulation must always be tightly wrapped around the ducts.

Outdoor air and discharge air ducts in cold rooms

It is recommended that outdoor air and extract air ducts are insulated with a minimum of 50 mm insulation finished with aluminium foil. Insulate the outdoor air duct to prevent hot air in the attic from heating the outside air during summer.

Be careful to seal where the exhaust duct passes through the roof or out through the gable to avoid condensation damage.

Contact your local supplier for guidance on national insulation guidelines.

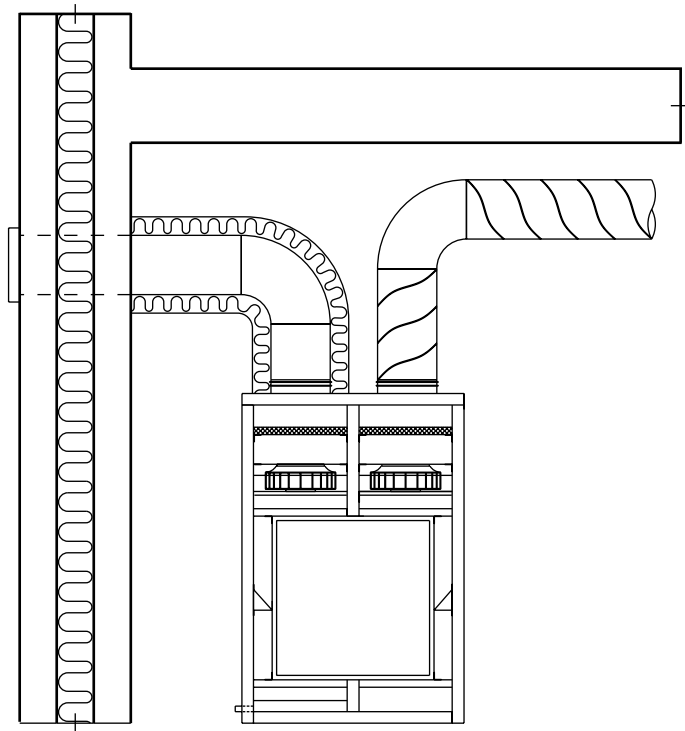

Insulation of ducts in heated rooms

We recommend the following:

Supply air and extract air ducts

In a warm attic, the supply air and extract air ducts must have 50 mm of insulation finished with aluminium foil.

Supply air and extract air ducts routed through heated rooms in the home do not need to be insulated unless cooling, a bypass or a geothermal heat exchanger are used. In this case, the supply air duct must be insulated. In this case, the supply air duct must be insulated.

Outdoor air and discharge air ducts

In warm attics and heated rooms in the home, outdoor air and exhaust ducts must have a minimum of 50 mm of insulation. Furthermore, the outside of the insulation must be covered with plastic or aluminium foil to prevent condensation water in the insulation.

Contact your local supplier for guidance on national insulation guidelines.

When using a geothermal heat exchanger, it is recommended to add 100 mm of insulation to the outdoor air duct.

Reheating supply air

The counter flow heat exchanger cannot fully recover all heat from exhaust air to supply air, so during winter the supply air will be approximately 1-4°C lower than the ambient temperature in the property. If the system is intended for use in heating, then a water or electric heating surface can be installed to heat the supply air to room temperature.

Water heating surface

To protect the water heating surface against frost cracking, a water frost sensor must be installed on the system and the water heating surface must be insulated. The water frost sensor is installed on the back of the slats of the water post-heating surface. The sensor for controlling the motor valve is installed in the supply air duct approximately 500 mm after the water heating surface so that it is not affected by radiant heat from the heater. The water connection to the water heating surface must be carried out by an authorised plumber.

Electric heating surface

The sensor for controlling the electric heating surface is installed in the supply air duct approximately 500 mm after the electric heating surface so that it is not affected by radiant heat from the heating unit.

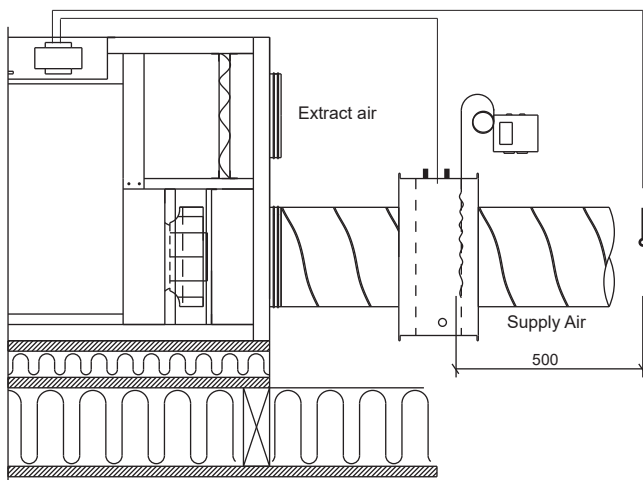

With water heating surface

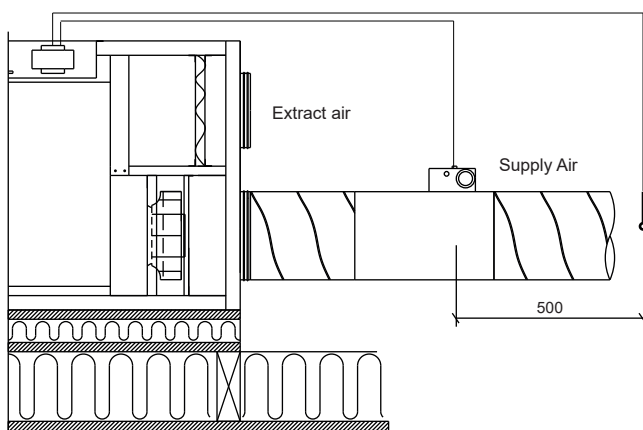

With electric heating surface

Preheating outdoor air

Electric preheater

At outdoor temperatures below 0°C and if software deicing cannot be used, we recommend installing an electric preheater to prevent ice from accumulating in the counter flow heat exchanger.

It may be beneficial to use a factory-fitted, integrated electric preheating surface (add-on accessory).

Electrical installation

Connection to the mains must be carried out by an authorised electrician. See the accompanying wiring diagram.

ECO 300/ECO 300 XL is prepared for external connection of a 230 volt device plug, internet and display, BMS connection and Genvex accessories.

See electrical diagrams and operating instructions for the Optima 270 for further information



Important!

For functional and safety reasons, the unit must be connected to a grounded socket suited to the plug.

Control and calibration of the system

To achieve optimal system operation, it must be commissioned using air measuring equipment.

If the system needs to be used before it is adjusted, then the following can be done before commissioning the system:

1. Check that the ECO 300/ECO 300 XL has been mounted correctly and that all ducts are properly insulated.
2. Check that the front cover can be dismantled so that it is possible to carry out service and maintenance on the unit.
3. Check that the filters are clean (they may become dirty after installation).
4. Check that the condensate drain is correctly fitted with a drain trap and is protected from frost. Pour 1 litre of water into the condensation water tray and ensure that it drains freely through the condensate drainpipe.
5. Set all supply air valves so that the valve plugged into the unit opens 3 turns from the closed position, while the outermost valve opens 8 turns from the closed position. The intermediate ones are opened between 4-7 depending on how close they are to the unit.

Set all exhaust air valves so that the exhaust air valve in the kitchen opens 8 turns, the exhaust air valve in the bathroom/toilet opens 7 turns and the extraction valve in the utility room opens 6 turns from the closed position.

6. If a heating element is fitted to the system, the supply air temperature is set to 0-3°C below the room temperature in the property.

The system can now be put into operation and may operate until the system is calibrated using ventilation measuring equipment.



Connections for internet, display, BMS and add-on accessories for the ECO 300/ECO 300 XL.

Optimal initial calibration of the system

We recommend that the ventilation unit should be calibrated by an authorised Genvex dealer before it is put into operation.

Before starting the initial calibration, check that the 6 points in the section "Control and calibration of the system" have been performed. Then start the unit:

Set the initial basic ventilation value, which is speed 2. To reduce energy consumption as much as possible, first adjust the main air volumes to the desired levels by adjusting the speed of the fans via the control panel.

Then adjust the supply air and exhaust air valves with air measuring equipment (during the initial calibration of the valves, remember to lock them and turn the baffle plate in the supply air valves so that the air blows in the right direction).

Then check the main air volumes again and fine-tune them using the fresh air and exhaust air valves (remember to lock the position of the valves after initial calibration).

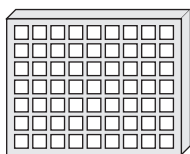

G4/Coarse = Standard filter (coarse filter class G4)

F7/ePM1 = Pollen filter (fine filter class F7)

System maintenance

REMEMBER TO SWITCH OFF THE POWER BEFORE OPENING THE UNIT.

Filters

When the filter timer reaches the set value for a filter change, this will appear in the text of the Optima Touch display or in the Genvex app or be indicated with a yellow flashing light in Optima Basic. This means that the filters must be replaced/cleaned.

The system is stopped by pulling the plug out of the socket or via the switch on the electrical panel. The front doors are opened and the filters removed. Once the filters have been cleaned/replaced, the front doors are closed and the filter alarm can now be reset via the display or app. The system then returns to normal operation.

If you want to replace the filters with a different time interval, this can be done via the user menu.



Do not vacuum or clean the filter using pressurised air. This will damage the filter!

Filter replacement

1. Open the filter plug.



2. Carefully pull out the filter and replace it with a new filter.



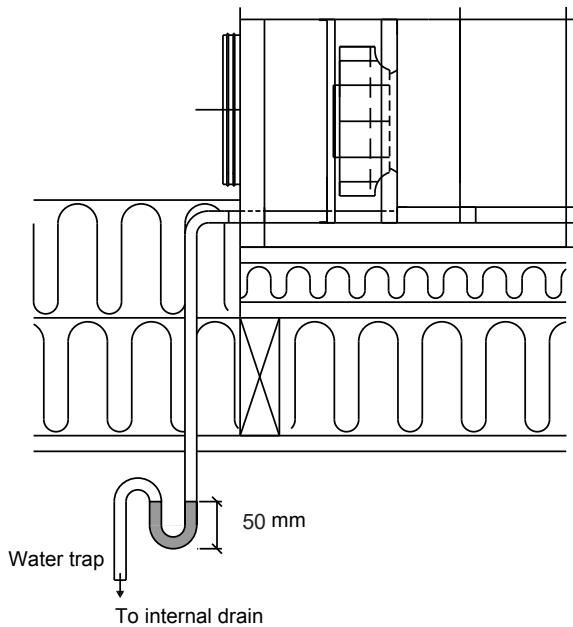

Condensate drain

During the filter change before autumn, the condensate drain should be checked to ensure it is not clogged with dirt and to ensure there is water in the drain trap.

Pour 1 litre of water into the condensation water tray and ensure that it drains away freely. If the condensation water drain does not function properly, then this may result in water damage to your home.

Counter flow heat exchanger

Inspect the counter flow heat exchanger annually. If it is dirty, remove the unit and wash it in lukewarm water with soap and rinse it in the bathroom with a shower head.

Fans

Remember to turn off the power.

Annually check the fan wheels for dirt.

Remove the front cover of the unit. Clean the fans with a brush or bottle cleaning brush. Note: please do not remove the balancing weights on the fan wheels, as this will lead to an imbalance in the unit with a higher noise level and cause more wear on the fans.

Supply air and exhaust air valves

Clean the vents by wiping them with a dry cloth. Ensure the vent does not rotate causing the airflow to change.

Service

If you are unable to maintain your system, you can sign a service agreement with the Genvex service department. If the system is faulty, please contact the Genvex service department.

Access to internal parts

1. Remove the screws from the front plate to access internal parts.



2. Disassemble the bracket with the sensor mounted in the exchanger. The exchanger can then be pulled out.



3. If a level sensor is installed in the system, this must be unscrewed before the fan housing can be removed.



4. Dismantle the fan housing by pulling on it.



5. Dismantle the bypass by releasing the plug on the side of the cassette.



6. Separate the two plastic flaps. The bypass cassette can then be pulled out.



7. Remove the six screws on the cover at the top of the system to gain access to the printed circuit board.

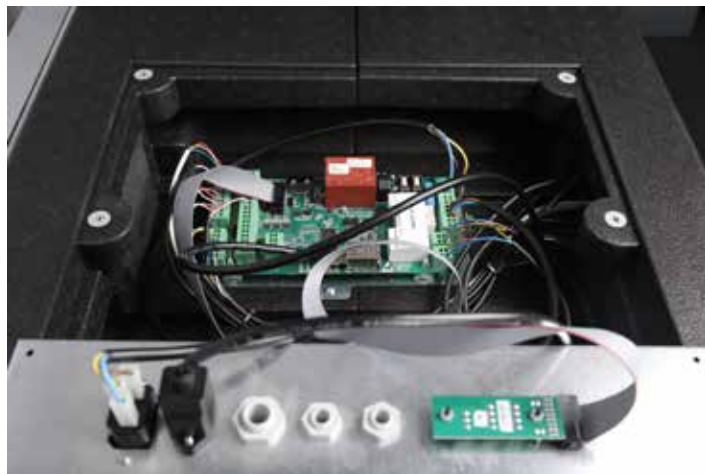

Recommended maintenance intervals

Component	Maintenance	Interval
Filter	Replaced at set intervals so the unit is fully efficient.	3-6 months
Fans	Fans must be cleaned with a soft brush to ensure operational safety and efficiency.	12 months
Counter flow heat exchanger	Clean with water	12 months
General gaskets	Give the gaskets on the unit a general check to ensure they are intact	12 months
Supply air and exhaust air valves	Check for dirt inside the supply air and exhaust air valves. Clean as needed. Check that the valves have the desired setting in relation to air volumes.	12 months
Air intake	Check for dirt and grime inside the air intake and exhaust air vents and clean as needed	12 months
Ventilation ducts	Check the cleanliness of ducts and clean as needed.	10 years

SPARE PARTS

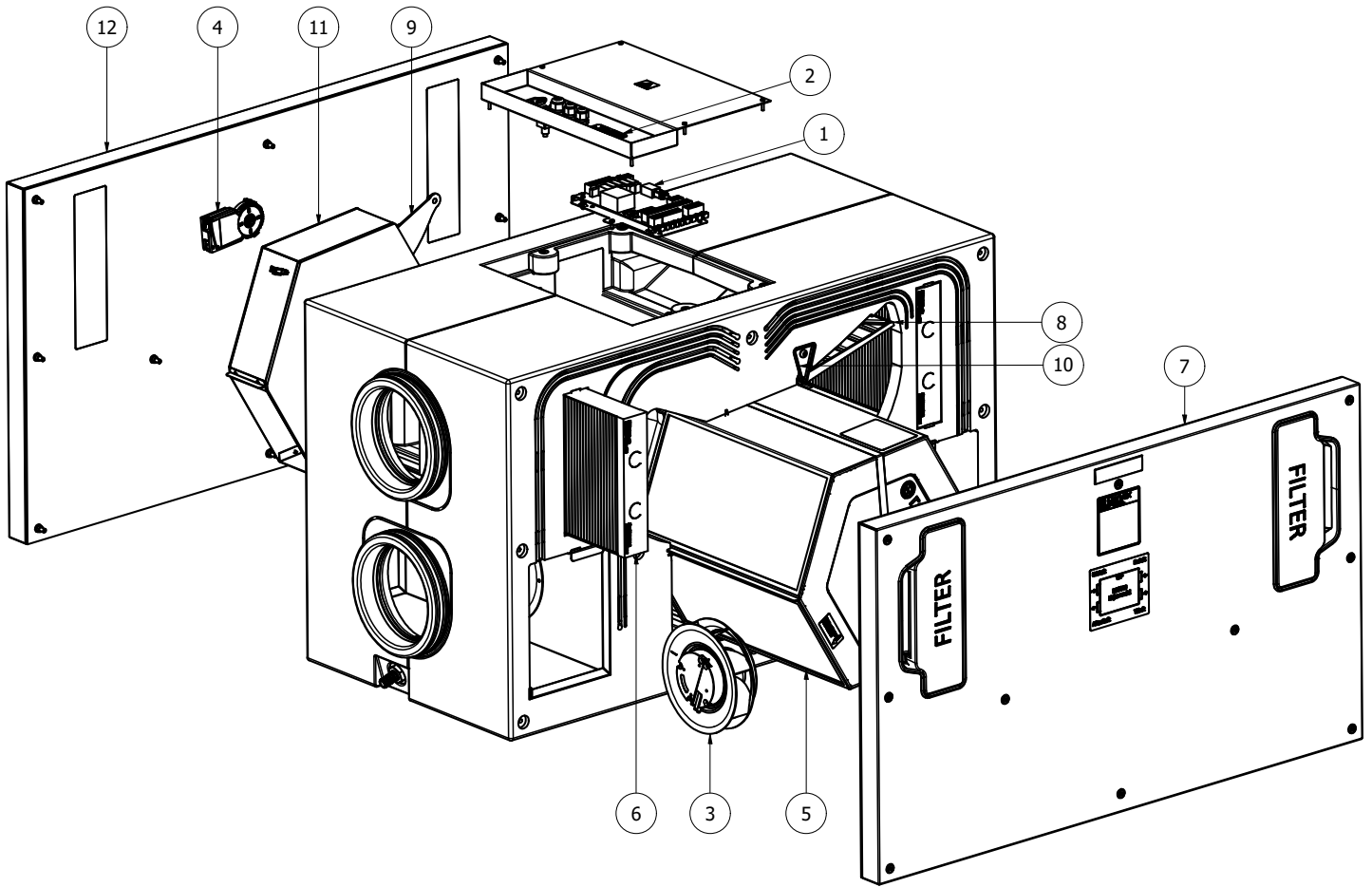

Pos.	Item no.	Description
1	069875	OPTIMA 270 PCB
2	069876	I/O PCB
3	070056 EC 070055 EC	90 Watt fan 170 Watt fan (XL)
4	070130	Bypass motor
5	072014	Counter flow exchanger
6	073001	Filter - F7 / ePM1 55%
6	073006	Filter - G4 / Coarse 65%
7	073034	Assembled front cover
8	073041	Bypass flap, large
9	073042	Bypass flap, small
10	073045	Bypass mounting bracket
11	073046	Assembled bypass cassette
12	073047	Assembled rear cover

TROUBLESHOOTING

System not running

- Fuse in electric panel has blown, no voltage in the system.
- One of the fuses in the system's control board has blown.
- Loose cable, no voltage to the unit.
- Incorrectly set weekly program.
- Filter timer has switched off the system.

No supply air

- Defective supply air fan.
- Clogged supply air filter.
- Outdoor air grille clogged with dirt and leaves during autumn or snow and ice during winter.
- Fuse on control board has blown.
- Unit is defrosting (supply air fan runs at reduced speed)
- Incorrect setting of Optima controls

No exhaust air

- Defective exhaust fan.
- Clogged exhaust filter.
- Fuse on control board has blown.

Cold supply air

Fault

- Heat exchanger is clogged.
- The exhaust fan is defective.
- The exhaust air filter is clogged.
- Disconnect the electric preheating surface from the overheating thermostat (only systems with an electric preheating surface installed).
- Air in heating pipe, defective thermostat/motor valve, incorrect setting of control panel.

If none of the above errors are relevant, contact:

- During the warranty period (0-2 years), the installer from whom the unit was purchased.
- After the warranty period (2+ years), the installer from whom the unit was purchased or call the Genvex Customer Centre on +45 7353 2700.

Please have the information from nameplate ready.

Alerts

See Optima 270 operating instructions.

ELDIAGRAM - OPTIMA 270

Service menu EC 10 = Right

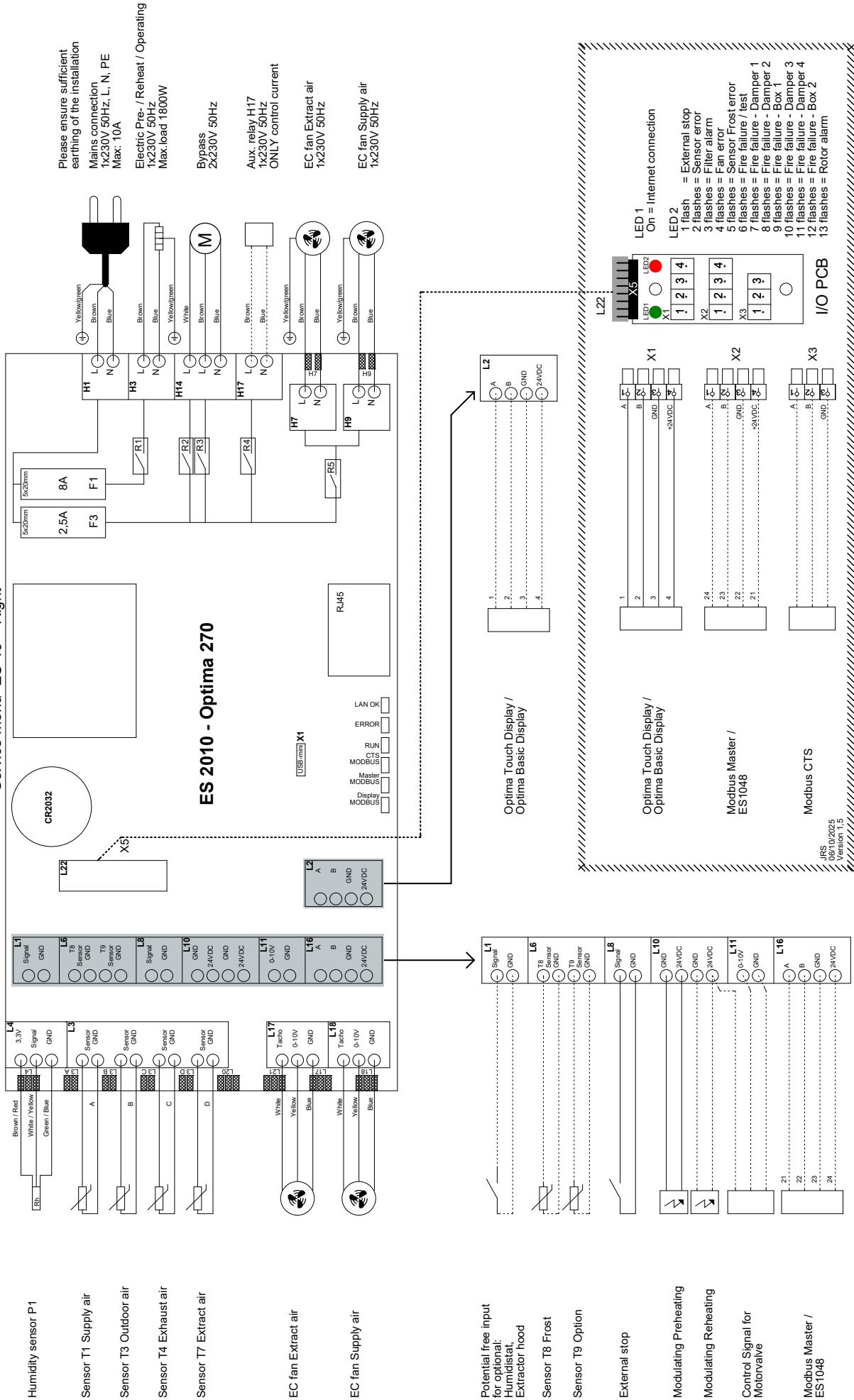

Please ensure sufficient earthing of the installation
Meins connection
1x230V 50HZ, L, N, PE
Max: 10A

Electric Pre- / Reheat / Operating
1x230V 50HZ
Max.load 1800W

Bypass
2x230V 50HZ

AUX relay H17
1x230V 50HZ
ONLY control current

EC fan Extract air
1x230V 50HZ

EC fan Supply air
1x230V 50HZ

DECLARATION OF CONFORMITY

The declaration of conformity can be found on our website: www.genvex.com

THE AIR WE BREATHE

All
Genvex
systems are
rated with
energy label
A

As of 1 January 2025, Genvex has merged with our parent company METRO THERM into one company under the name METRO THERM A/S.

With the merger, both physical addresses will be retained: The head office and production for METRO THERM will remain in Helsingør, while administration and production for Genvex and KVM-Conheat will remain at the Haderslev address as a subdivision.

The three strong brands – METRO THERM, Genvex and KVM-Conheat – remain unchanged and will continue to be treated as independent brands under METRO THERM A/S.



Genvex – the original Danish ventilation system

Genvex is a true Danish original. We started producing ventilation systems in 1978 and are still the front runners when it comes to development and production of the most innovative and durable ventilation systems on the market.

Our units are installed in thousands of homes, providing clean, fresh air free from pollen, dust and harmful particles. They help lots of families with maintaining a healthy and comfortable indoor climate and prolong the longevity of the house itself. With very high heat recovery rates, a Genvex system lets you recover and reuse up to 95 % of the heat inside your home. As a result, our units provide a strong contribution to energy savings in both in family homes and in society as a whole.



08-471-2601