

INSTALLATION MANUAL



ECO 190 XL

Mechanical ventilation with passive heat recovery

TABLE OF CONTENTS

Safety information	3
Installation	4
Duct connection.....	6
Duct system	6
Condensate drain	7
Insulation of ducts in cold attics	7
Insulation of ducts in heated rooms.....	8
Post-heating of the supply air	8
Electrical Installation	9
Control and adjustment of the system.....	9
Optimal initial adjustment of the system	10
System maintenance.....	10
Trouble shooting	11
Optional equipment for the ECO 190 XL ventilation unit	12
Spare parts	13
Electrical diagram - OPT270	14
Declaration of conformity	16
Disassembly instructions	17

SAFETY INFORMATION

This manual also describes installation and service work to be performed by a professional.

This appliance can be used by children aged 8 and over and by people with reduced physical, sensory and mental abilities, as well as people with a lack of experience and knowledge, provided they are supervised or have received guidance on using the appliance in a safe way and understand the dangers involved. Children must not play with the appliance. Cleaning and user maintenance must not be performed by children without supervision.

Subject to change.

Labelling

The CE label represents METRO THERM's assurance that the product complies with all regulations imposed on the product in accordance with relevant EU directives. The CE label is mandatory for most products sold in the EU, irrespective of where they are made.

INSTALLATION

IMPORTANT:

Follow these instructions when installing the ECO 190 XL:

1. Turn off the electricity before opening the unit.
2. Install an airtight water trap in a frost-free place to compensate for the fan pressure.
3. The water trap must have a height of at least 50 mm.
4. Make sure that the condensate drain has a sufficient slope (min. 1%) towards the sewer.
5. Pour 1 litre of water into the drip tray of the unit to check that it drains correctly. Make sure the condensate drain is filled with water before each heating season.
6. If the condensate drain is exposed to frost, a thermostat and an electric tracing cable must be installed to prevent the drain from freezing if the temperature drops below +2°C.
7. Initial adjustment must be carried out on both the supply and extract air sides before using the machine. It is important that there is a balance between the volumes of intake and extract air.
8. It is recommended keeping the ventilation ducts closed until the unit is started and the system has been adjusted.

The ECO 190 XL is intended for mounting in the ceiling with the special brackets supplied with the ventilation unit (see photos).

Important: The ECO 190 XL can only be mounted horizontally.

1. Install the ceiling brackets in accordance with the size of the ventilation unit with a total of 6 screws able to hold the full weight of the unit.
2. Slide the ventilation unit with the pre-assembled flanges onto the ceiling brackets.
3. Complete the installation by installing a screw in the mounting hole to ensure that the ventilation unit cannot be tilted out of the ceiling bracket.
4. Fine adjustment of the ECO 190 XL so that the machine is level, and adjustment to the ceiling, can be performed by adjusting the machine's flanges via the screws indicated by the arrows in picture 2.

The ECO 190 XL is intended to be mounted flat on a level, vibration-free surface. The default configuration is "right", which means that the supply and extract air from the living areas of the house is connected to the right side of the ventilation unit (when the main control board of the machine is facing you). Labels on the ventilation unit indicate how the ductwork is to be connected.

PLEASE NOTE that project-specific models can be configured for left-hand connection - if this is the case, the labels indicate how the ductwork should be connected.

For information on reconfiguring a "right-hand" unit into a "left-hand" unit, contact your Genvex sales representative.

On a "right-configured" model, the condensate drain and water trap are connected on the left side of the ventilation unit (i.e. on the side for fresh air and discharge). The condensate drain on the right side will be plugged and not in use.

The recommended required installation space is the machine size including brackets +20 cm all around the unit. At least 160 cm of clearance below the machine is recommended for filter replacement and general servicing. When planning installation of the ECO 190 XL, take into account the space required for the water trap/condensate drain.

METRO THERM A/S always recommends careful planning of the installation space for your Genvex product in relation to the location of living spaces. As this is a technical product that contains fans and/or a heat pump, in rare cases, and in combination with inappropriate installation conditions, it can produce unsatisfactory noise or vibration nuisances. As a general rule, it is always recommended installing the technical system so that it is not placed in the immediate vicinity of a bedroom. At the same time, when attaching the Genvex system to the building structure, it is recommended attaching to a heavy structural component such as concrete. It should also be ensured that no sound or vibrations can be transmitted through materials in contact with the technical system. If there is a risk of propagation of noise and vibrations, further installation of vibration-damping material and sound-damping of installation rooms are recommended.

The above instructions must be followed. If the installation is not carried out in accordance with these instructions, METRO THERM cannot be held liable for any further damage that has nothing to do with the Genvex unit.

1.



2.



3.



ECO 190 XL

Dimensional sketch (in mm)

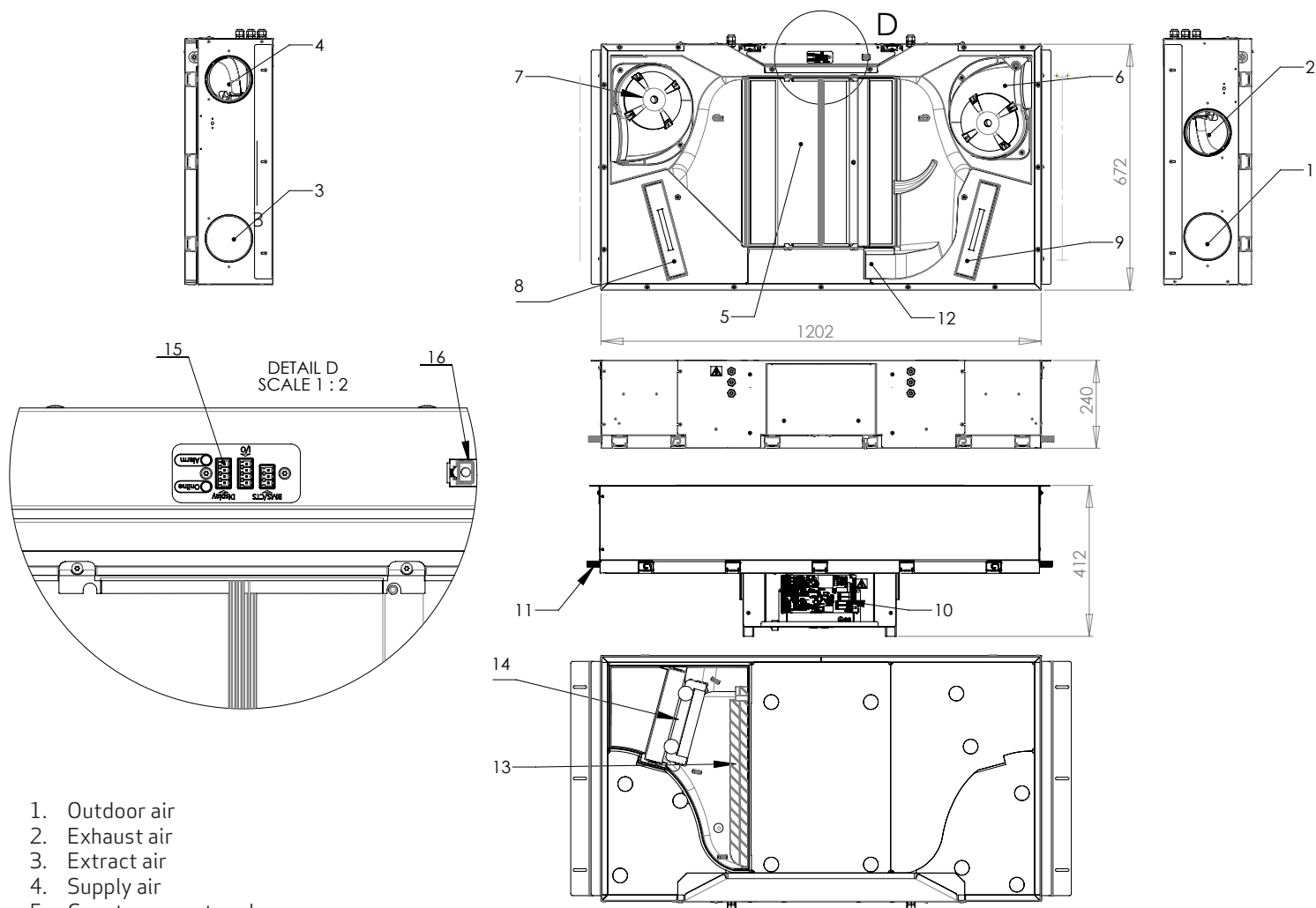

1. Outdoor air
2. Exhaust air
3. Extract air
4. Supply air
5. Countercurrent exchanger
6. Supply air fan
7. Discharge air fan
8. Fresh air filter
9. Extract air filter
10. Electrical connection
11. Condensate drain
12. Bypass
13. Bypass flap
14. Preheater
15. IIO Print (connection for display, external Genvex components and Modbus)
16. NJ45 Adapter

Note that the unit shown above is configured as a “right-hand” model and without additional equipment (e.g. folding base plate, condensate water pump, etc.).





Duct connection

At all duct connections, a yellow sticker is affixed, indicating which ventilation ducts are to be connected to the various connection pieces.

Supply air is connected 
Duct system from unit to supply to living room.

Extract air is connected 
Duct system from damp rooms to the unit.

Fresh air is connected 
Duct system from fresh air hood/fresh air grate from the open air or from earth exchanger to unit.

Discharge is connected 
Duct system from unit to discharge hood/discharge grate to the open air.

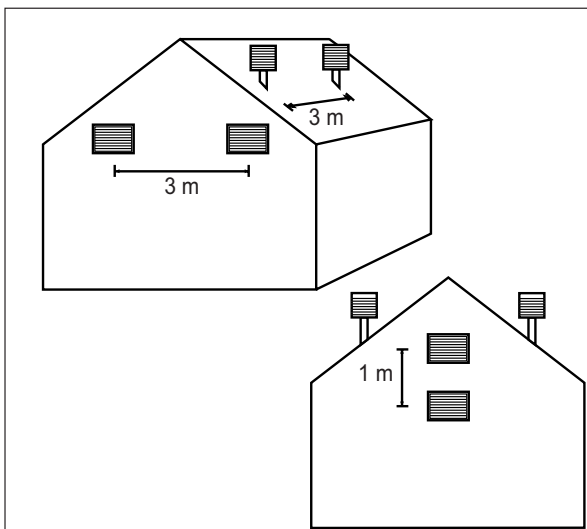

Duct system

It is recommended that the duct system should be made from spiral ducting, assembled with fittings with rubber ring seals to ensure a tight and long-lasting duct system. In order to achieve a satisfactory low noise level from the unit, a damper must always be fitted to the supply and extract duct system between the unit and the first supply and extract fittings.

It is recommended dimensioning the air speeds in the ducts at a sufficiently low level so that no noise is generated by the supply and extract fittings.

When positioning fresh air and discharge hoods/grates, ensure that the two air currents do not short-circuit, and thereby prevent the discharge air being sucked in again. It is recommended that grates should be placed on the north or east side of the house to achieve optimal comfort in homes/flats.

It is recommended that the air intake should be placed on the north or east side of the house to achieve maximum comfort and the least possible impact of solar heating.

The recommended minimum horizontal distance between air intake and discharge: 3 metres.

The recommended minimum vertical distance between air intake and discharge: 1 metre.

In order to connect regular galvanised steel ducts to the ECO 190 XL ventilation unit, you must first install 4 nipple connectors in the unit's Ø125 mm openings (double sealing lips). The unit is now ready for direct connection of ductwork to the nipple connector.

It is recommended installing galvanised angle braces to fasten the nipple connector to the galvanised housing using self-tapping steel screws.



Condensate drain

The units produce up to 6 litres of condensate per day. It is therefore important that the condensate drain is executed correctly, and that the unit has a slope towards the condensate drain side.

The water trap must be airtight, and the Genvex bottle trap with 2 x Ø15 mm hose connections can be used advantageously. Between the drain connection on the unit and the water trap, a reinforced water hose is used, which is fastened with a hose clamp on both connections.

In general, the condensate drain is executed with a required slope of 1%. If the unit is mounted in a cold attic, the condensate drain must be insulated so that the condensate in the pipe does not freeze. It is also recommended installing the water trap in an underlying warm room to ensure that the water in the water trap does not freeze. If you are not able to protect the condensate drain against freezing by means of insulation, it is necessary to mount a thermostat-controlled heating band around the condensate drain pipe.

During operation, a negative pressure is created in the unit, which means it is necessary to ensure that the water trap contains a water column of at least 50 mm.



Insulation of ducts in cold attics

To benefit from the unit's high recovery potential (efficiency), the ducts must be correctly insulated.

Supply and extract ducts

In order to minimise heat loss from the duct system in cold attics, supply and extract ducts must be provided with at least 100 mm of insulation. If insulation from alternative A is used, it is recommended that it be executed with two layers of 50 mm lamella mats with paper or foil externally and with staggered joints between the two layers. If the ducts are laid on the main beams of truss frames, alternative B can be used. The insulation must always be packed tightly around the ducts.

Fresh air and discharge ducts in cold areas

It is recommended providing fresh air and discharge ducts with at least 50 mm of insulation. The fresh air duct is insulated to prevent hot air in the attic from heating the fresh air in summer. Be sure to seal the end where the outgoing duct is passed through the roof or through the gable in order to prevent condensation damage.

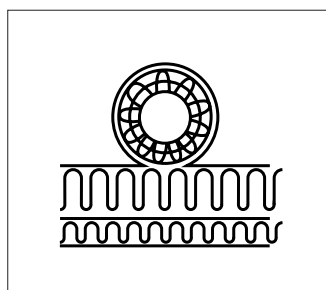

Duct insulation, alt. A

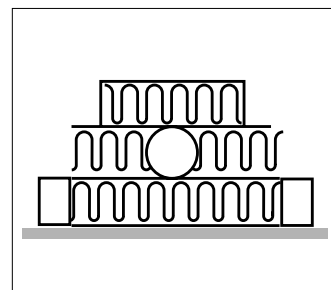

Duct insulation, alt. B

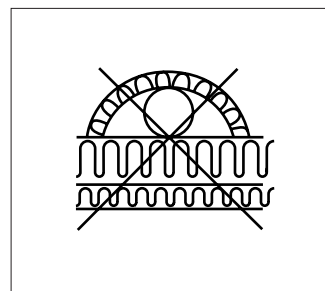

Faulty duct insulation

Insulation of ducts in heated rooms

We recommend the following:

Supply and extract ducts

In a warm attic, the supply and extract ducts must be provided with 50 mm of insulation finished with aluminium foil.

Supply and extract ducts routed through heated rooms in the home need not be insulated unless cooling, bypass or geothermal heat exchangers are used. In such cases, the supply duct must be insulated.

Fresh air and discharge ducts

In warm attics and heated rooms in the home, fresh air and discharge ducts must be provided with a minimum of 50 mm of insulation. In addition, the insulation must be lined on the outside with plastic or aluminium foil to prevent condensation in the insulation.

Contact your local supplier for advice on national guidelines on insulation.

When using a geothermal heat exchanger, it is recommended adding 100 mm of insulation to the fresh air duct.

Post-heating of the supply air

Since the countercurrent heat exchanger cannot recover all the heat from the extract air to the supply air, in the winter season the supply air will be approx. 1–4°C lower than the room temperature in the home. If it is desired to use the system for heating, a water or electric heating surface able to heat the supply air to room temperature can be installed.

Capacity

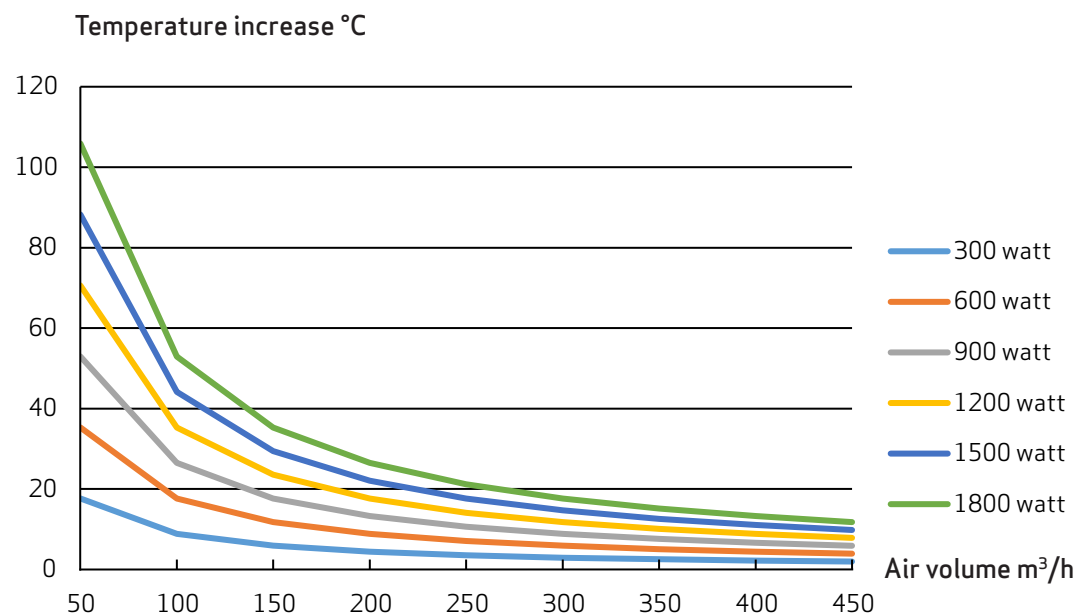

The diagram shows the temperature increase of the air for different air volumes after it has passed through the heating surface. To ensure as low an energy consumption as possible, the lowest possible power must be selected (this primarily applies to the on/off heating surface).

Water post-heating surface

To protect the water post-heating surface against frost burst, a water frost sensor must be installed on the water post-heating surface and the water post-heating surface must be insulated. The water frost sensor is installed on the back of the slats of the water post-heating surface. The sensor for controlling the motor valve is installed in the supply duct approx. 500 mm after the water post-heating surface so that it is not affected by radiant heat from the heater. The water connection to the water post-heating surface must be executed by an authorised plumber.

Electric post-heating surface

The sensor for controlling the electric heating surface is installed in the supply duct approx. 500 mm after the electric heating surface so that it is not affected by radiant heat from the heater.

Electric preheater

At outdoor temperatures below 0°C, it is recommended installing an electric preheater to prevent ice accumulation in the countercurrent heat exchanger. The sensor for controlling the electric preheater must be installed in the fresh air duct 500 mm before the electric preheater (in the case of an on/off preheating surface).

Note - when a modulating preheating surface with a solid state relay is used, the existing fresh air temperature sensor in the ventilation unit can be used to control the preheater (no additional temperature sensor is required).

With a factory-fitted, integrated preheating surface, it is recommended using the built-in discharge temperature sensor as a reference sensor (see Optima 270 operating instructions for configuration).

1.



2.



Electrical installation

The electrical connection must be executed by an authorised electrician. See wiring diagrams.

“Important: for safety reasons, the machine must be connected to a socket with grounding adapted to the plug connection”

Access to the control board is obtained by removing the safety screw as shown in the picture. See picture 1.

The Optima 270 control board can then be pulled down via the integrated rail system, and the terminals are now freely accessible for connecting additional equipment. See picture 2.

A display (accessory) is connected to the socket marked with “display” on the outside of the cabinet.

A CTS system is connected to the Modbus connection marked “BMS/CTS”.

Fire/district heating/CO₂ sensors are connected to the Modbus connection marked “I/O”.

An internet/router is connected to the RJ45 connection outside the cabinet.

Also see “Operating instructions, Optima 270” for further details.

Control and adjustment of the system

To achieve optimal operation of the system, it must be adjusted using specialist ventilation measuring equipment. If you wish to put the system into operation before adjusting it, you can do the following:

Before putting the system into operation

1. Check that the Genvex unit is correctly installed and that all the ducts are properly insulated.
2. Check that the base plate can be opened so that it is possible to service and maintain the unit.
3. Check that the filters are clean (may be dirty after installation).
4. Check that the condensate drain is correctly installed with a water trap and protected against frost. Pour 1 litre of water into the condensate tray and check that it runs through the condensate drain unhindered.
5. Set all supply valves such that the valve closest to the unit is opened 3 turns from the closed position and the outer valve is opened 8 turns from the closed position. The intermediate valves are opened between 4 and 7 turns, depending on how close they are to the unit.
6. If a reheating surface is installed in the system, the supply air temperature is set to 0–3°C below the room temperature in the home.

The system can now be put into operation and run until the system is adjusted using specialist ventilation measuring equipment.

Optimal initial adjustment of the system

We recommend that the ventilation unit should be adjusted by an authorised Genvex dealer before commissioning.

Before starting the initial adjustment, make sure that the six points in the section on inspection and initial adjustment have been completed. Then start the unit:

Set the initial basic ventilation value, which is speed 2. To reduce energy consumption as much as possible, first adjust the main air volumes to the desired air volume by adjusting the speed of the fans via the control panel.

Then adjust the supply and extract valves with air measuring equipment (during initial adjustment of the valves, remember to lock them and to rotate the baffle in the supply valves so that the air blows in the right direction).

Then check the main air volumes again and precisely adjust the main air volumes using the fresh air and extract air valves (remember to lock the valves in position after initial adjustment).



System maintenance

REMEMBER TO SWITCH OFF THE POWER BEFORE OPENING THE UNIT.

Filters

When the filter timer reaches the set value for a filter replacement, this will appear in the text in the Optima Touch display or be indicated by a yellow, flashing light on the Optima Basic. This means that the filters must be replaced/cleaned.

The system is stopped at the system switch or the switch at the switchboard. The filter flaps are opened as indicated and the filters removed. When the filters have been cleaned/replaced, the front doors are closed and the filter alarm can now be reset. The system then returns to normal operation.

If you want to replace the filters with a different time interval, this can be done via the user menu.

 **Do not vacuum or clean at high air pressure. This will damage the filter!**

Condensate drain

In connection with the filter replacement carried out before the autumn, check the condensate drain for any clogging with dirt, and check whether there is water in the water trap. The water trap cannot dry out because, due to the negative pressure of the unit, air will be sucked into the unit and the unit will not be able to get rid of the condensate.

Pour 1 litre of water into the condensate tray and see if it drains unhindered. If the condensate drain is not working, there is a risk of water damage to the home.

Countercurrent heat exchanger

Inspect the countercurrent heat exchanger. If it is dirty, take it out and wash it in warm soapy water and then rinse it, e.g. in the bathroom using the shower head.

 **The heat exchanger plates must be handled carefully. They have sharp edges and must not be damaged.**

Fan

Check the two fan wheels for dirt. If they are dirty, they can be cleaned with a brush, bottle washer, etc.

Supply and extract valves

Clean the valves by wiping them with a dry cloth. Make sure that the valve does not rotate and thus cause a change in the air volume.

Important: When reinstalling the front plate on the ventilation unit, do not use power tools to tighten the bolts, as this may result in damage to the threaded connections. Carefully tighten all the front-plate bolts until the plate is firmly seated on the cabinet of the ventilation unit.

TROUBLESHOOTING

Safety thermostat in electric heating surface (accessory)

If a fault occurs on an electric heating surface, the safety thermostat will switch off. The electric heating surface is equipped with a fire thermostat, which automatically shuts off the power if the temperature exceeds 50°C. When the temperature drops, the heating surface automatically switches back on.

As extra security, there is a built-in thermal fuse, which switches off if the temperature exceeds 100°C. Reconnection must be performed manually. This does not apply to PTC electric heating surfaces.

System not running

System stopped

Fault

- Fuse in electric panel has blown, no voltage in the system.
- One of the fuses in the system's control board has blown.
- Loose wire, no voltage to the unit.
- Loose wire between the unit and the control panel.
- Defective or incorrectly set weekly program.
- Filter timer has switched off the system.

Condensate leaking from the unit

Possible fault

- Condensate drain clogged with dirt.
- Condensate drain not adequately protected against freezing at low outdoor temperatures.

Fault on air side

No supply air

Fault

- Defective supply fan.
- Clogged supply filter.
- Fresh air grate clogged with dirt and leaves in the autumn or snow and ice in the winter.
- Fuse on control board has blown.
- Unit is defrosting (supply fan speed reduced)
- Incorrect setting of Optima control.

No extract air

Fault

- Defective extract fan.
- Clogged extract filter.
- Fuse on control board has blown.

Cold supply air

Fault

- Heat exchanger is clogged.
- Extract fan is defective.
- Extract filter is clogged.
- The electric reheating surface is switched off at the over-heating thermostat (only systems with electric post-heating surface installed).
- Air in heating pipe, defective thermostat/motor valve, incorrect setting of control panel.

If none of the mentioned faults, contact:

- **During the warranty period (0-2 years)**
the installer from whom the unit was purchased.
- **After the warranty period (2 years ->)**
the installer from whom the unit was purchased or Genvex's customer centre on tel. +45 7353 2700.

Please have the data from the type plate ready (silver plate on the unit).

Alarms

See operating instructions, Optima 270

Frost alarm

This fault is displayed if a water post-heating surface is installed on the system and the temperature on the water post-heating surface is too low, entailing a risk of frost burst. The control will stop the system and open the engine valve to keep the heating surface warm.

OPTIONAL EQUIPMENT FOR THE ECO 190 XL VENTILATION UNIT

(available on request to Genvex)



Condensation level switch – must be connected to “external start/stop” on the main circuit board for automatic shut-off of the ventilation unit if the condensate drain is blocked.



Tilting base plate – used for integration in suspended ceilings and ensures accessibility for servicing. The tilting base plate is available in white (RAL9016) and with 20 mm of sound-absorbing insulation.



Integrated preheating surface – the ECO 190 XL can be supplied with an integrated electric heating surface that ensures balanced air volume even at cold outdoor temperatures.



Condensate pump – the ECO 190 XL can be supplied with a factory-fitted condensate pump that makes it possible to divert condensate even in difficult conditions (Note: only recommended in combination with condensation level switch)

SPARE PARTS

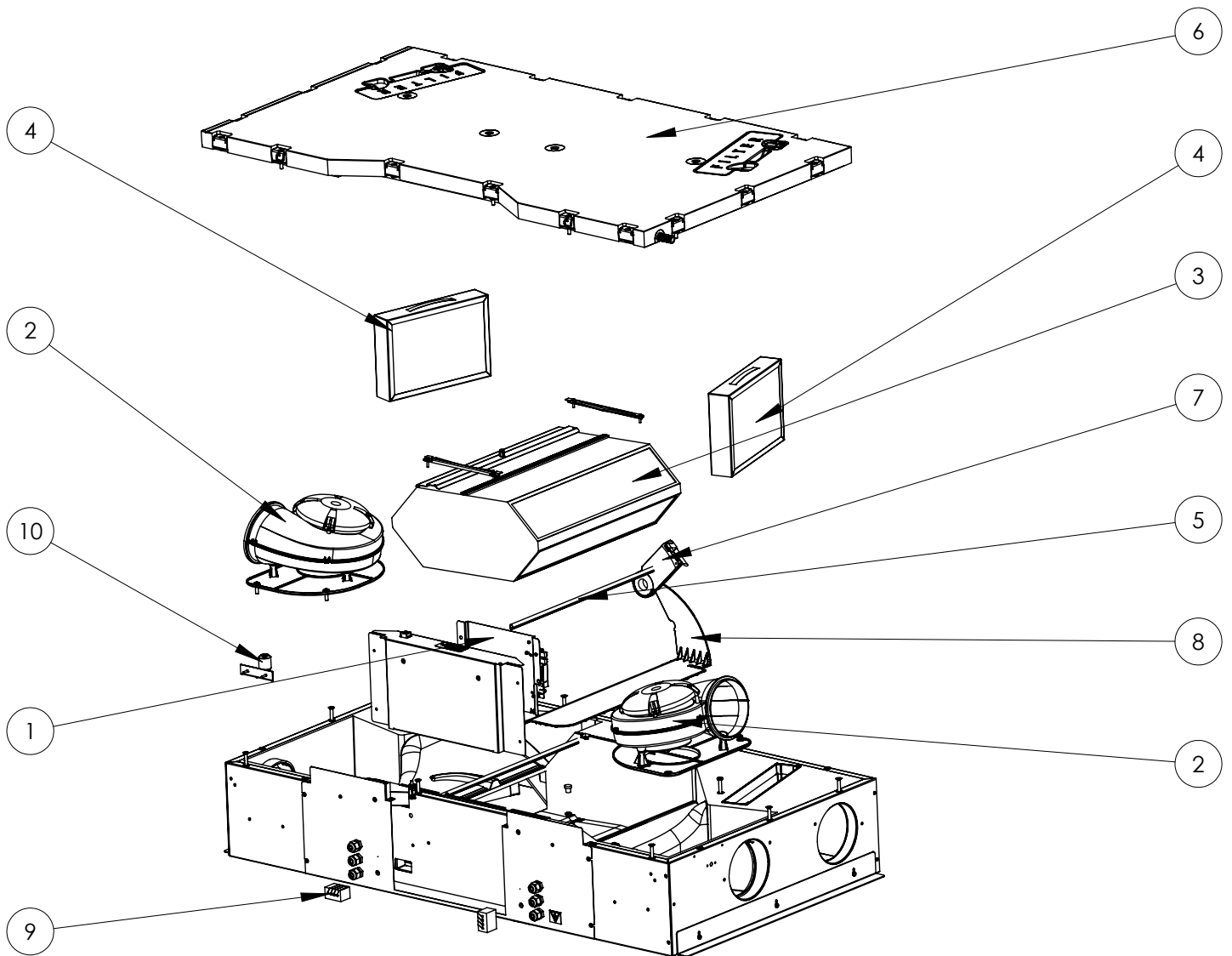

No.	Item no.	Description
1	069875	Optima 270 print
2	069820	XL Fan, incl. cabinet
3	069344	Exchanger GS18 x 460 alu
	069345	Exchanger GS18 x 460 plastic
4	069370	Filter G4/Coarse
	069371	Filter M5/ePM10
	069372	Filter F7/ePM1

No.	Item no.	Description
5	069221	Packing list
6	069382	Base plate, assembled
7	060536	Belimo motor CM230-FR
8	069761	Bypass flap, large
9	069354	Cable entry 2
10	069365	Level switch complete

DECLARATION OF CONFORMITY

The declaration of conformity can be downloaded from www.genvex.com.

DISASSEMBLY INSTRUCTIONS



Remove fan



Remove heat exchanger



Remove condensation level switch



Remove bypass actuator

THE AIR WE BREATHE

All
Genvex
systems are
rated with
energy label
A

As of January 1, 2025, METRO THERM has merged with KVM-Genvex A/S into a single entity under the shared name METRO THERM A/S.

The three well-known brands – METRO THERM, Genvex and KVM-Conheat – will continue as before, as is also the case for our production and administration sites, which will continue unchanged at our facilities in Helsingør and Haderslev.

The merger is a natural progression of our strong collaboration and a strategic decision to strengthen our position as one of Northern Europe's leading suppliers of heating, hot water, and ventilation solutions.



Genvex – The original Danish Ventilation System

Genvex is a genuine Danish original. We invented the ventilation system more than 40 years ago, and we are still ahead of the pack when it comes to development and production of the strongest and most durable ventilation system.

Our unit is working in thousands of homes providing fresh clean air – free of pollen, dust and harmful particles. This helps to strengthen the health of the house and to make the indoor environment healthy and comfortable for lots of families. At the same time, our system is an important element when it comes to saving energy in homes and in society as a whole – in fact you can recover up to 95% of the heat energy with a Genvex system.



08:701-2601