

INSTALLATION MANUAL



ECO 175

Mechanical ventilation with passive heat recovery

TABLE OF CONTENTS

Safety information	3
Functional description	4
Installation	5
Wall mounting (vertical connections)	6
Dimensional sketch	7
Duct connection (top).....	8
Condensate drain	10
Duct system	11
Insulation of ducts in cold attics	12
Insulation of ducts in heated rooms.....	12
Electrical installation	13
Control and calibration of the system.....	13
Optimal initial calibration of the system.....	13
System maintenance	14
Filters.....	14
Access to internal parts.....	15
Preheating surface.....	16
Fan	16
Supply air and exhaust air valves	16
Recommended maintenance intervals	17
Spare parts	18
Troubleshooting	19
Safety thermostat in electric heating surface	19
System not running.....	19
No supply air.....	19
No exhaust air	19
Cold supply air	19
Alerts	19
Circuit diagram, Optima 270 - right	20
Circuit diagram, Optima 270 - left	21
Declaration of Conformity	22
Deinstallation instructions	23

SAFETY INFORMATION

This manual also describes installation and service work to be performed by a professional.

This appliance can be operated by children aged 8 and over, by persons with reduced physical, sensory and mental abilities, and by persons with a lack of experience and knowledge, provided they are supervised or have received guidance on using the appliance in a safe way and understand the dangers involved. Children must not play with the appliance. Cleaning and user maintenance must not be performed by children without supervision.

Subject to design changes.

Labelling

The CE mark represents METRO THERM's assurance that the product complies with all regulations laid down for the product in accordance with relevant EU directives. The CE mark is mandatory for most products sold in the EU, irrespective of where they are made.

FUNCTIONAL DESCRIPTION

ECO 175 is a ventilation system for residential comfort ventilation.

The machine is equipped with a high-efficiency counterflow heat exchanger, which recovers the heat from the extract air leaving the home and preheats the fresh supply air.

ECO 175 can be configured as both right and left facing, depending on installation conditions.

A modulating electric preheater can be added to the system to maintain balanced air volumes – even in very cold outdoor temperatures.

ECO 175 has been designed for indoor installation, but can also be used outside the building envelope in areas protected from wind and weather, if the specific country requirements allow it.

INSTALLATION

The machine should only be used when connected to an electrical installation with an earth connection that complies with regulations. It must also be ensured that the earth connection of the electrical installation is matched to the earth plug of the unit.

IMPORTANT!

Follow these instructions when installing the ECO 175:

1. Turn off the electricity before opening the unit.
2. Install an airtight water trap in a frost-free place to compensate for the fan pressure.
3. The drain trap must have a height of at least 50 mm.
4. Ensure that the condensate drain has a sufficient grade (at least -1%) towards the sewer.
5. Pour 1 litre of water into the condensate tray of the unit to check that it drains correctly. Make sure the condensate drain is filled with water before each heating season.
6. If the condensate drain is exposed to frost, a thermostat and an electric tracing device must be installed to prevent the drain from freezing when the temperature drops below +2°C.
7. Before commencing operation, adjustments must be made on both the supply and exhaust air sides. It is important that to ensure a balance between the amounts of intake and exhaust air.
8. We recommend that you keep the ventilation ducts closed until the unit is started and the system is calibrated.

These instructions must be followed. If the installation is not carried out in accordance with these instructions, METRO THERM cannot be held liable for any potential further damage that is not caused by the Genvex unit itself.

Genvex always recommends careful planning of the installation space for your Genvex product, considering the location of living spaces. As this is a technical product that contains fans and/or a heat pump, in rare cases, and in combination with inappropriate installation conditions, it may cause unsatisfactory noise or vibration. As a general rule, it is always recommended to install the technical system so that it is not located in the immediate vicinity of a bedroom. Furthermore, when securing the Genvex unit to the building structure, it is recommended attaching it to a heavy structural component such as concrete.

It should also be ensured that no sound or vibrations can be transmitted through materials in contact with the technical system. If there is a risk of propagation of noise and vibrations, further installation of vibration-damping material and sound-damping of installation rooms are recommended.

As a minimum, duct silencers must be installed from ventilation systems and towards living areas (supply and extract air). It may also be beneficial to install sound dampening between rooms to avoid ducted sound from one room to another. Depending on the environment, duct silencers on outdoor air and exhaust connections may also be necessary.

Duct silencers are dimensioned according to Genvex noise data for the individual product and in consultation with a professional. General reference is made to building regulations and project-specific requirements (e.g. DGNB) for permissible sound level limits.

Wall mounting

Before starting installation of the ventilation unit

Make sure that the wall used to hold the ventilation unit is built in such a way that it is able to support the weight of the unit. In addition, the wall must be straight and plumb.

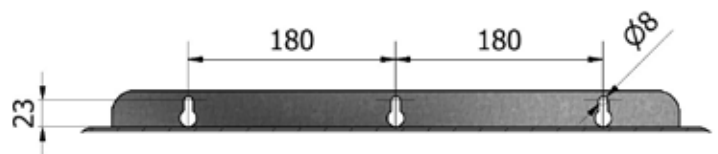

Diagram 1

ECO 175 comes with pre-mounted wall brackets as shown in Diagram 1.

Before mounting the ECO 175, fit three Ø6-8 mm bolts into the wall. The bolts should be installed level according to the dimensions as shown in Diagram 1.

Once bolt mounting is complete, the ECO 175 is hung over the bolts via the keyholes in the wall bracket.

The system must be mounted level to ensure drainage from the condensate tray.

Dimension chart - left facing version (dimensions in mm)

To allow service and maintenance access, there must be a clearance of at least 600 mm in front of the ECO 175.

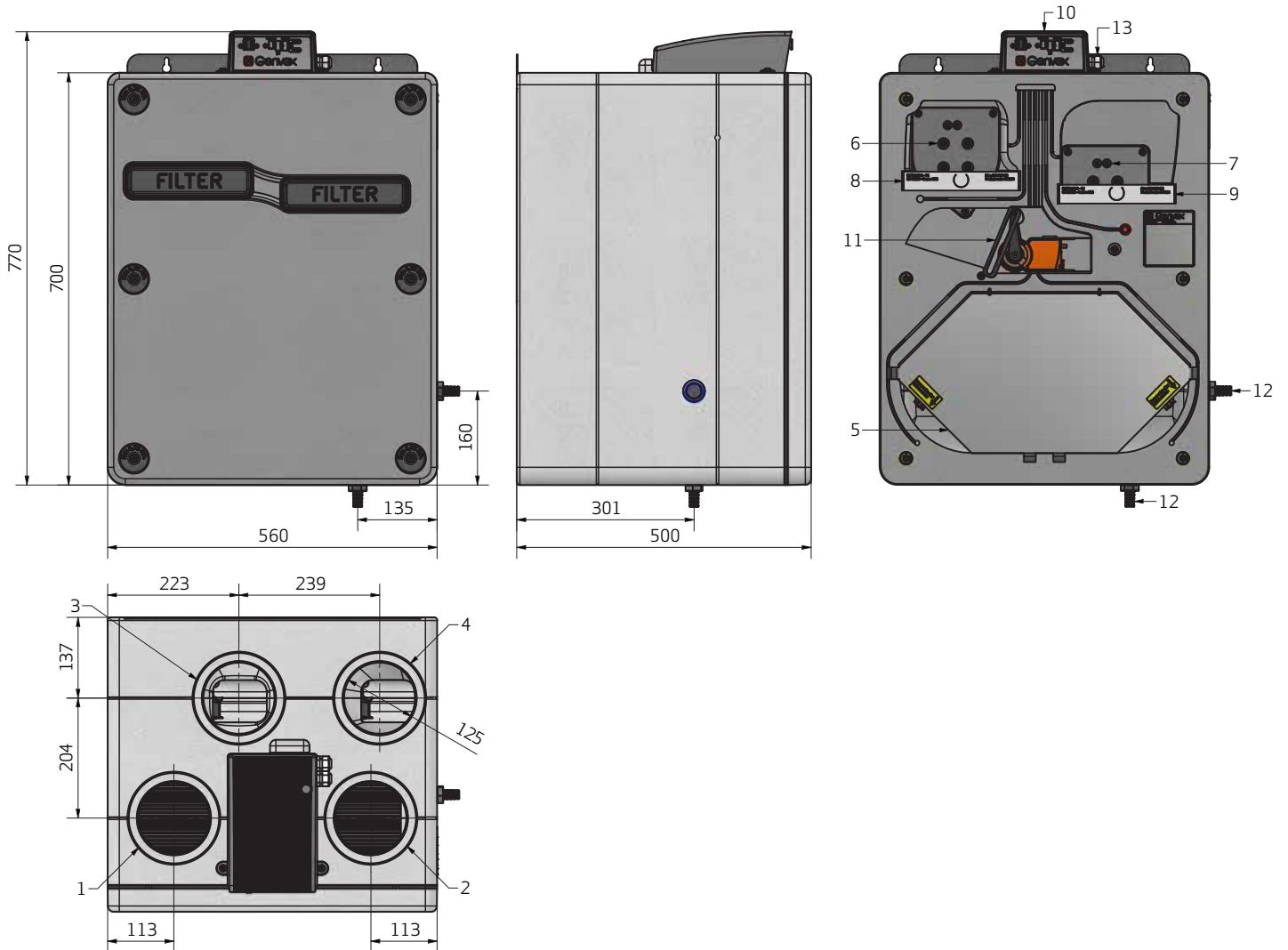

- | | |
|-------------------|-------------------------------|
| 1. Extract air | 8. Exhaust filter |
| 2. Outdoor air | 9. Supply air filter |
| 3. Supply air | 10. Print |
| 4. Exhaust air | 11. Bypass |
| 5. Heat exchanger | 12. Condensate drain |
| 6. Supply air fan | 13. External power connection |
| 7. Exhaust fan | |

Dimension chart - right facing version
(dimensions in mm)

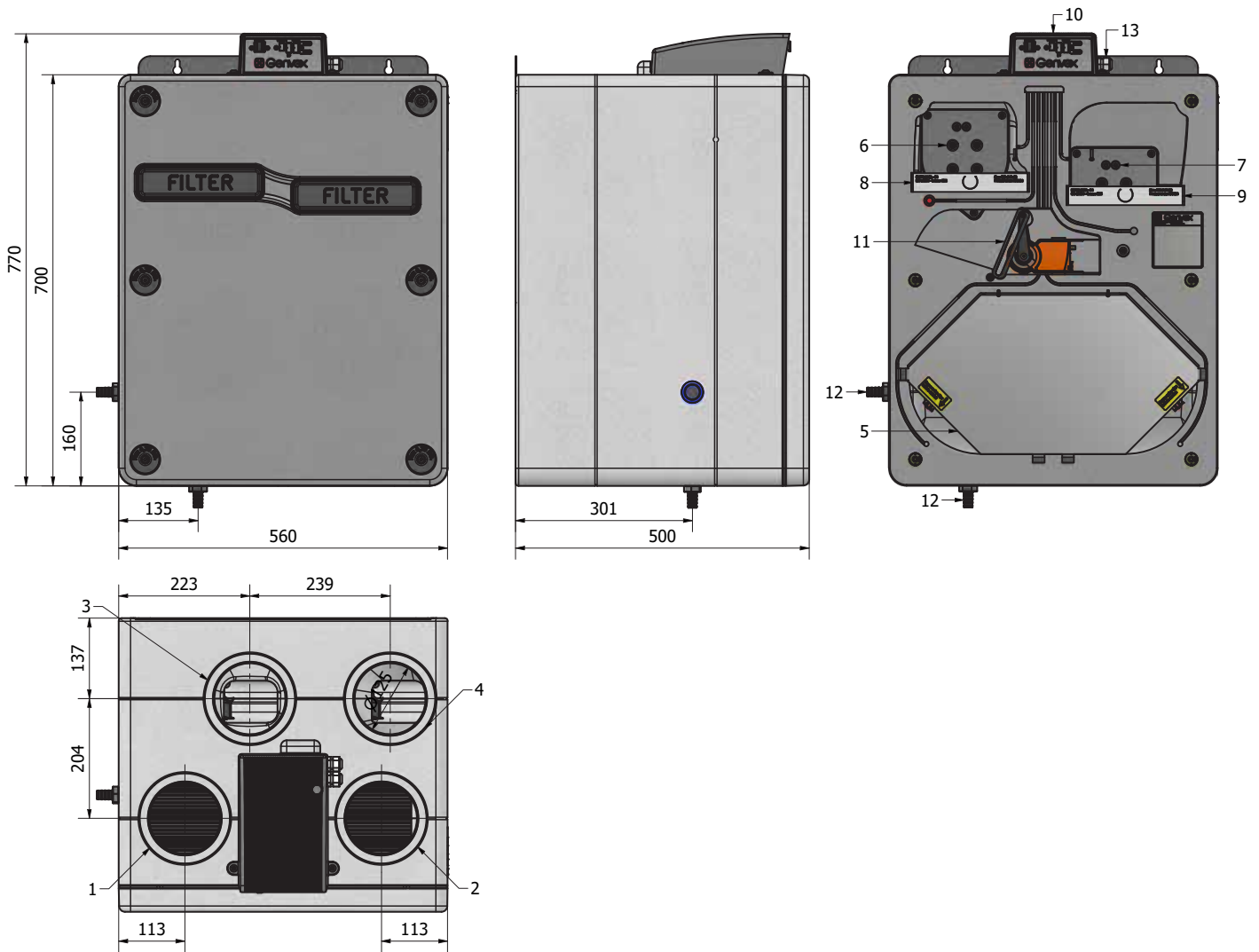

- | | |
|-------------------|-------------------------------|
| 1. Outdoor air | 8. Supply air filter |
| 2. Extract air | 9. Exhaust filter |
| 3. Exhaust air | 10. Print |
| 4. Supply air | 11. Bypass |
| 5. Heat exchanger | 12. Condensate drain |
| 6. Exhaust fan | 13. External power connection |
| 7. Supply air fan | |

Duct connection (top)

A yellow label is attached to the top of the unit, indicating which ventilation ducts should be connected to the different outlets depending on whether the unit is configured as right or left facing.

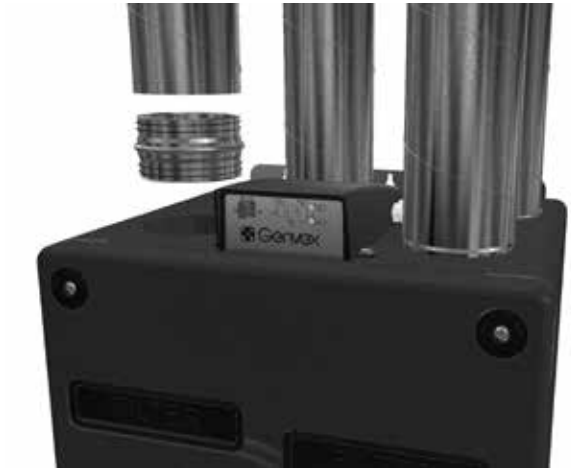
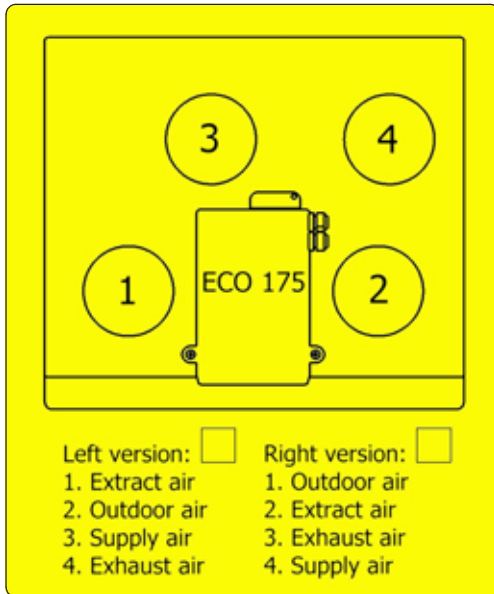

It is possible to convert a right facing unit to left facing and vice versa by repositioning the humidity sensor.

For more details on conversion, contact your Genvex sales representative.

To start the duct installation, we recommend using 4x Ø125 connectors with double sealing lips.

Illustration of wall hung and horizontal installation

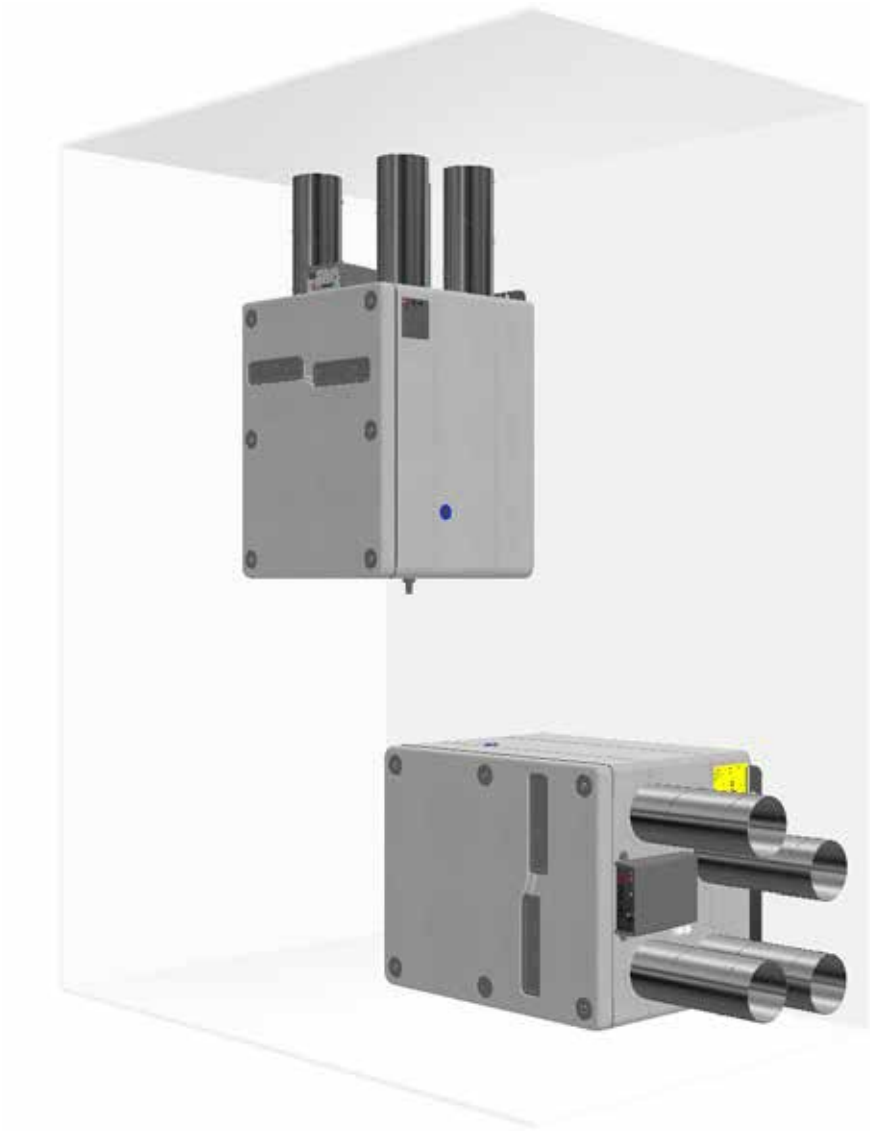

Condensate drain

The ventilation unit produces up to 6 litres of condensate per day. It is therefore important to mount the condensate drain correctly. An ordinary Ø15 mm hose can be connected directly to the ventilation unit.

It is important to make a "pigtail" on the hose to create a water trap with a minimum water column of 50 mm.



There must be a downward gradient of 1% from the drain trap and the hose towards the drain itself. If the unit is installed in a cold environment, the condensate drain must be insulated to prevent the condensate from freezing inside the pipe. However, it is recommended that the drain trap is installed in a heated area to ensure that the water inside does not freeze. If installation problems make it impossible to secure the condensate drain against frost by means of insulation, it is necessary to install a thermostatically controlled heating wire around the condensate drain.

During operation, internal negative pressure occurs in the unit. Therefore, it is necessary to ensure a water column height of at least 50 mm in the drain trap under all conditions.

ECO 175 comes with a plugged condensate drain.

Carefully tighten the included hose coupling nipple until the O-ring seals against the insert up into the thread connection where no plug is fitted. The condensate drain hose can then be connected to the hose coupling nipple.

Check the correct installation of the hose nozzle by pouring water into the condensation tray and placing a finger on the outlet of the hose nozzle. Check that no water exits the O-ring seal



Connecting the condensate drain

Installation examples - left/right + wallhung/lying

Only one condensate connection is required as indicated on the sketch below. The remaining condensate connections not in use shall be plugged and sealed airtight with the plugs supplied with the unit.

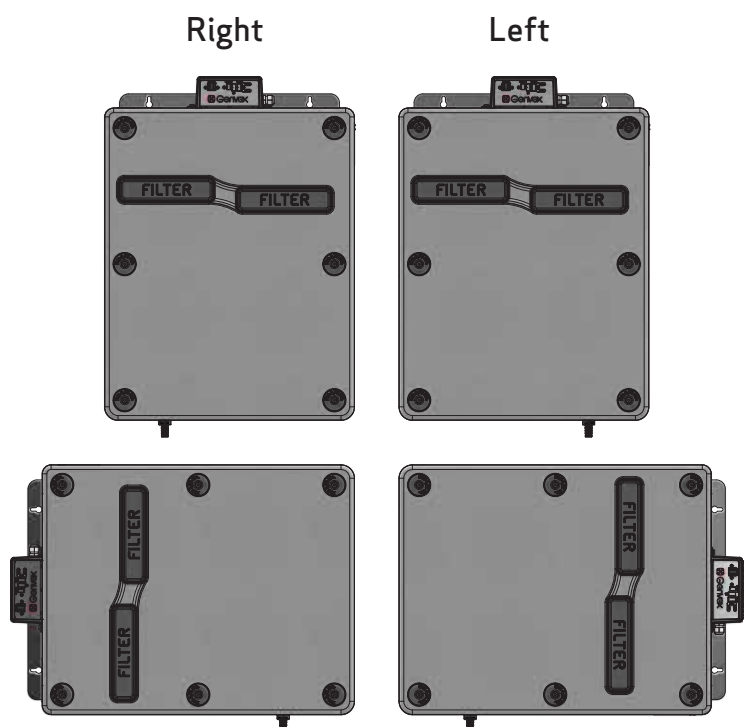



Duct system

It is recommended that the duct system should be made of spiral-folded pipes assembled with fittings with rubber ring seals so that you get a tight and durable duct system. In order to achieve a satisfactory noise level from the unit, sound locks must be installed on the supply air and exhaust air duct system between the unit and the first supply air and exhaust air vents.

To eliminate noise from the supply and exhaust air vents, it is recommended that the air velocities in the ducts are reduced to a sufficiently low level.

When positioning outdoor air and exhaust air hoods/gratings, it must be ensured that the two air flows do not short-circuit, thereby preventing the exhaust air from being sucked in again. It is recommended that bar screens are installed on the northern or eastern side of the house to achieve optimal comfort in houses/apartments. It is recommended that the air intake should be located on the north or east side of the house to achieve maximum comfort and minimal impact from the sun's heat.

The recommended minimum horizontal distance between air intake and exhaust air: 3 metres.

The recommended minimum vertical distance between air intake and exhaust air: 1 metre.

To connect standard galvanised steel ducts to the ECO 175 ventilation unit, you must first install 4 nipple connectors in the unit's Ø125 mm openings (double sealing lips).

The unit is now ready for direct connection of ductwork to the nipple connector.

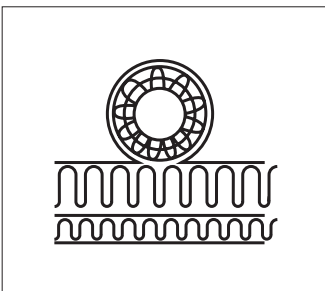
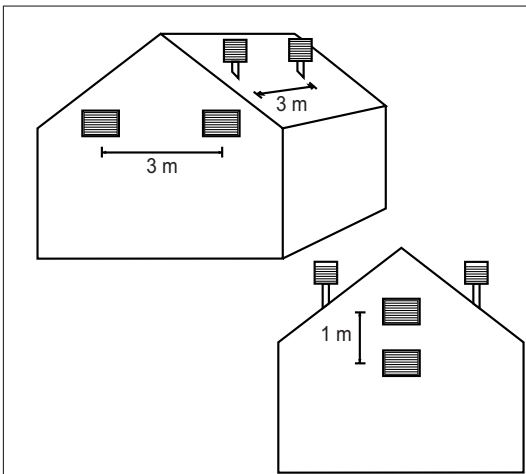

Ductwork insulation alternative A

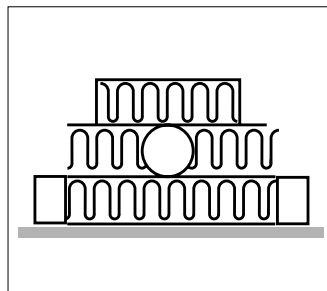

Ductwork insulation alternative B

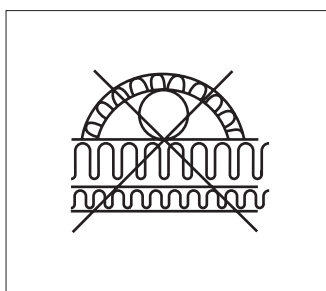

Wrong insulation

Insulation of ducts in cold attics

To benefit from the unit's high recovery potential (efficiency), the ducts must be correctly insulated.

Supply air and exhaust air ducts

In order to minimise heat loss from the duct system in cold attics, supply air and exhaust air ducts must be provided with at least 100 mm of insulation. If insulation from alternative A is used, it is recommended executing with two layers of 50 mm lamella mats with paper or foil externally and with staggered joints between the two layers. If the ducts are laid on the main beams of truss frames, alternative B can be used. The insulation must always be packed tightly around the ducts.

Outdoor air and exhaust air ducts in cold areas

It is recommended to insulate ducts for outdoor air and exhaust air ducts with at least 50 mm insulation. The outdoor air duct is insulated to prevent warm air in the attic from heating the fresh air in the summer. Be sure to seal the connection where the outgoing duct passes through the roof or gable to prevent condensation damage.

Insulation of ducts in heated rooms

Supply air and exhaust air ducts

In a warm attic, the supply air and exhaust air ducts must be provided with 50 mm of insulation finished with aluminium foil. Supply air and exhaust air ducts routed through heated rooms in the home do not need to be insulated unless cooling, a bypass or a geothermal heat exchanger are used. In this case, the supply duct must be insulated.

Outdoor air and exhaust air ducts

In warm attics and heated rooms in the home, outdoor air and exhaust air ducts must be insulated with a minimum of 50 mm insulation. In addition, the insulation must be lined on the outside with cling film or aluminium foil to avoid condensation inside the insulation.

Contact your local supplier for advice on the national insulation guidelines.

When using a geothermal heat exchanger, it is recommended to add 100 mm of insulation to the outdoor air duct.

Electrical installation

ECO 175 is prepared for connection to a 230 V socket with an earth (Schuko type). In addition, internet, display, CTS/BMS and Genvex accessories (e.g. CO₂ sensor) can be connected via the front of the system.



See wiring diagrams and operating instructions for the Optima 270 for more information.

In general, all electrical connections to ECO 175 must be carried out by an authorised installer.

If an additional external connection is required, an M16 coupling can be installed by removing the marked pre-cut cover (see the photo below).



Important!

For functional and safety reasons, the unit must be connected to a socket with an earth connector matched to the plug connection.

Control and commissioning of the system

To achieve optimal operation of the system, it must be calibrated using specialist ventilation measuring equipment. If it is desired to put the system into operation before commissioning, the following approach can be taken:

Before putting the system into operation

1. Check that the Genvex unit is correctly mounted and that all the ducts are properly insulated.
2. Check that the door can be opened so that it is possible to service and maintain the unit.
3. Check that the filters are clean (they may be dirty after installation).
4. Set all supply air valves so that the valve closest to the unit is opened 3 turns from the closed position and the outer one is opened 8 turns from the closed position. The intermediate valves are opened between 4 and 7 turns, depending on how close they are to the unit.

The system can now be put into operation and run until the system is calibrated using specialist ventilation measuring equipment.

Optimal initial commissioning of the system

Genvex recommends that the ventilation unit should be commissioned by an authorised Genvex dealer before it is put into operation.

Before starting the initial calibration, check that the 4 points in the section on control and calibration of the system have been performed. Then start the unit: Set the initial basic ventilation value, which is speed 2. To reduce energy consumption as much as possible, first adjust the main air flows to the desired air flow by adjusting the speed of the fans via the control panel.

Then adjust the supply air and exhaust air valves with air measuring equipment (during the initial calibration of the valves, remember to lock them and to turn the baffle plate in the supply air valves so that the air blows in the right direction).

Check the main air volumes again and fine-tune the main air volumes using the outdoor air and extract air valves (make sure to lock the position of the valves after the initial adjustment).

SYSTEM MAINTENANCE

Remember to switch off the power to the ventilation system before servicing.

Filters

When the filter timer reaches the set value for a filter change, this will appear in the text in the Optima Touch display or in the Genvex app, or be indicated by a yellow flashing light in Optima Basic. This means that the filters need to be changed.

Open the filter plugs and remove the filters. Once the filters have been changed, insert the new filters and click the filter plugs back onto the housing. 230V power is connected when the filter change is complete.

The filter alarm can now be reset via the display or the app. The system then returns to normal operation.

If you want to replace the filters using a different time interval, this can be adjusted in the user menu.

 Do not vacuum or clean at high air pressure. This will damage the filter!



Access to internal parts

To access internal parts of the ECO 175, the front plate must be removed.

IMPORTANT:

Disassembly of the front plate and exposure of live/moving parts may only be done by a professional.



1. Remove the screws from the front plate to access internal parts.



2. Disassemble the two sensor brackets and sensors mounted on both sides of the counter flow heat exchanger. The counter flow exchanger can then be carefully pulled out.



4. Remove the bypass by removing the motor arm screw from the bypass flap. The orange bypass motor can then be clicked out of the bracket and the motor power supply removed from the bottom of the motor.

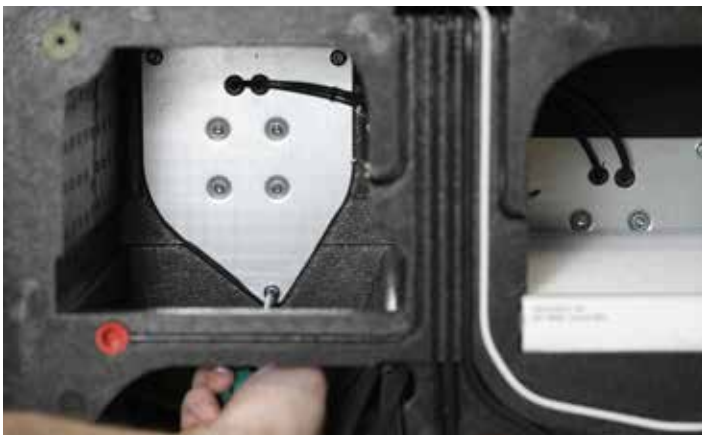

3. Remove the fan by unscrewing the fan plate - held in place by three screws on the outer edge of the plate.

Fan

Check the two fan wheels for dirt. If they are dirty, they can be cleaned with a brush, bottle washer or similar.

Supply air and exhaust air valves

Clean the valves by wiping them with a dry cloth.
Make sure that the valve does not rotate, thus causing a change in the air volume.

Important!

When reinstalling the fan and front plate on the ventilation unit, do not use electric tools to tighten the screws as this could result in damage to the threaded connections.
Carefully tighten all the screws until the front plate is firmly fitted on the cabinet of the ventilation unit.

Recommended maintenance intervals

Component	Action	Interval
Filter	Replaced at regular intervals so that full efficiency of the unit is achieved.	3-6 months
Fans	Fans must be cleaned with a soft brush to ensure operational safety and efficiency.	12 months
Counter flow heat exchanger	Clean with water	12 months
Gaskets in general	Check gaskets on the unit and make sure they are intact	12 months
Supply air and exhaust air valves	Check for dirt inside the supply air and exhaust air valves. Clean as needed. Check that the valves have the desired setting in relation to air volumes.	12 months
Air intake	Check for dirt and grime inside the air intake and exhaust air vents and clean as needed	12 months
Ventilation ducts	Check the cleanliness of ducts and clean as needed.	10 years



SPARE PARTS

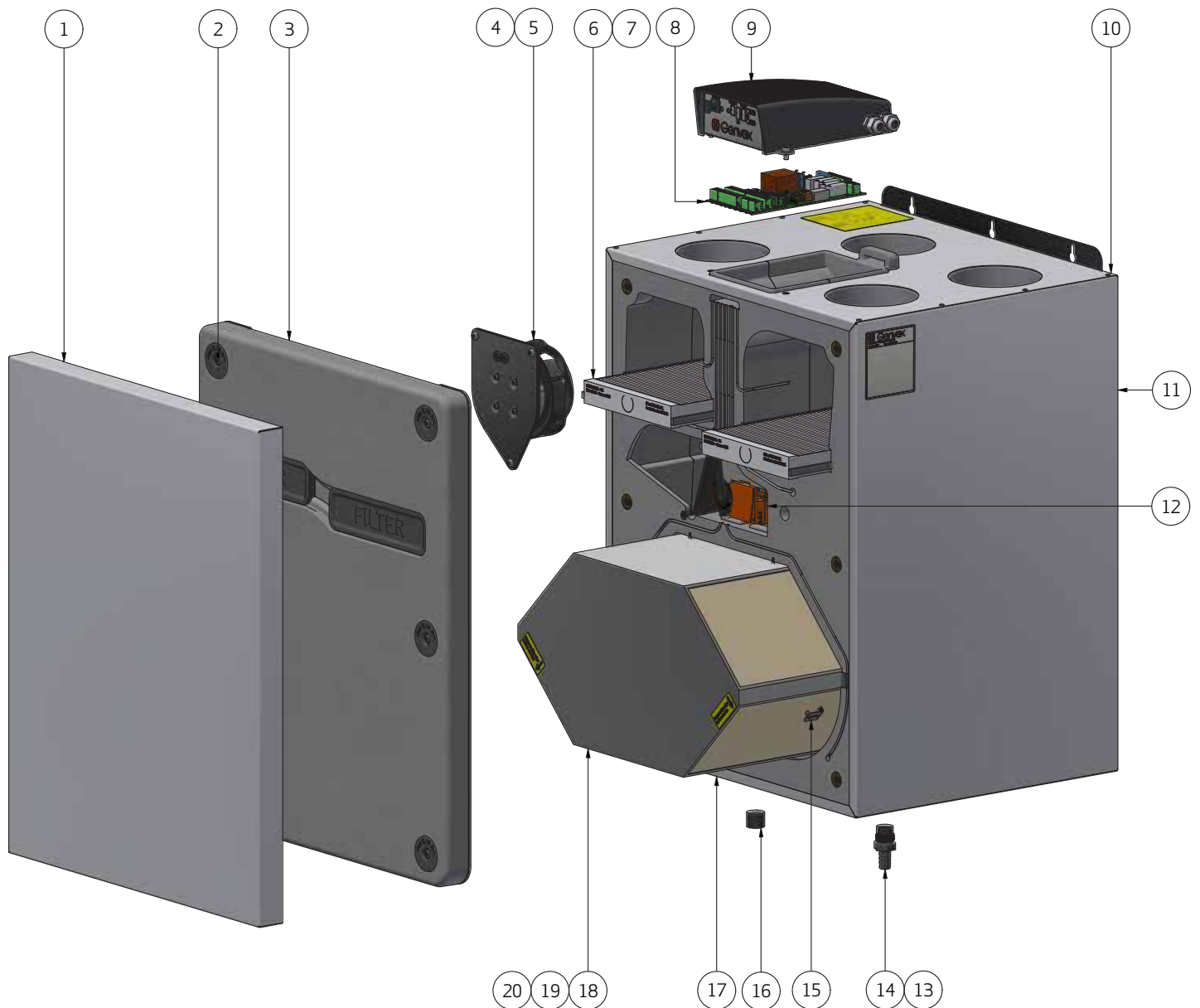

No.	Item no.	Description
1	075041	Front plate, white
2	070115	Screw M6 x 50
3	075009	Assembled front cover
4	069575	Fan lead-throughs
5	069819	Ebm Ø133 EC fan
6	075024	Filter G4
7	075036	Filter F7
8	069875	OPTIMA 270 PCB
9	075008	Complete electrical box
10	075039	Top cover RAL9016

No.	Item no.	Description
11	075038	Side cover RAL9016
12	070130	Bypass motor
13	072035	O-ring for drain connection
14	072034	Drain connection
15	069807	Sensor clip for exchanger
16	075013	Blind plug for condensate drain
17	075040	Base cover RAL9016
18	075020	Aluminium counter flow exchanger
19	075026	Plastic counter flow exchanger
20	075037	Entalpi counter flow exchanger

TROUBLESHOOTING

System not running

- Fuse in electric panel has blown, no voltage in the system.
- One of the fuses in the system's control board has blown.
- Loose cable, no voltage to the unit.
- Incorrectly set weekly program.
- Filter timer has switched off the system.

No supply air

- Defective supply air fan.
- Clogged supply air filter.
- Outdoor air grille clogged with dirt and leaves during autumn or snow and ice during winter.
- Fuse on control board has blown.
- Unit is defrosting (supply air fan runs at reduced speed)
- Incorrect setting of Optima controls

No exhaust air

- Defective exhaust fan.
- Clogged exhaust filter.
- Fuse on control board has blown.

Cold supply air

Fault

- Heat exchanger is clogged.
- The exhaust fan is defective.
- The exhaust air filter is clogged.
- The electric preheating surface is disconnected from the overheating thermostat (only for systems with an electric preheating surface are installed).
- Air in heating pipe, defective thermostat/motor valve, incorrect setting of control panel.

If none of the above errors are relevant, contact:

- During the warranty period (0-2 years), the installer from whom the unit was purchased.
- After the warranty period (2 years ->), the installer from whom the unit was purchased or the Genvex Customer Centre by calling 7353 2700.

Please have the data from the rating plate ready (silver plate on the unit).

Alerts

See Optima 270 operating instructions.

ELECTRICAL DIAGRAM OPTIMA 270 - RIGHT

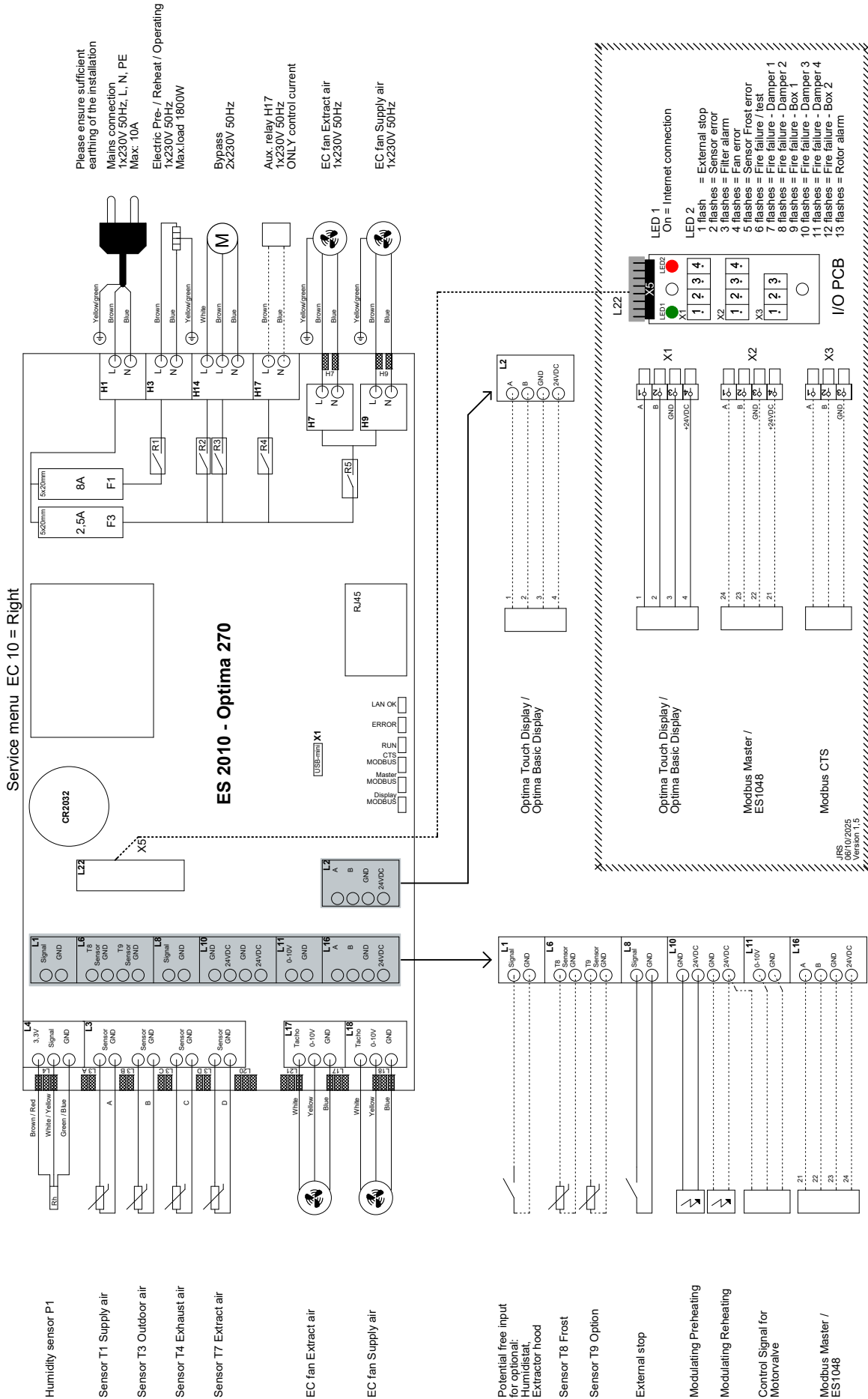

ELECTRICAL DIAGRAM OPTIMA 270 - LEFT

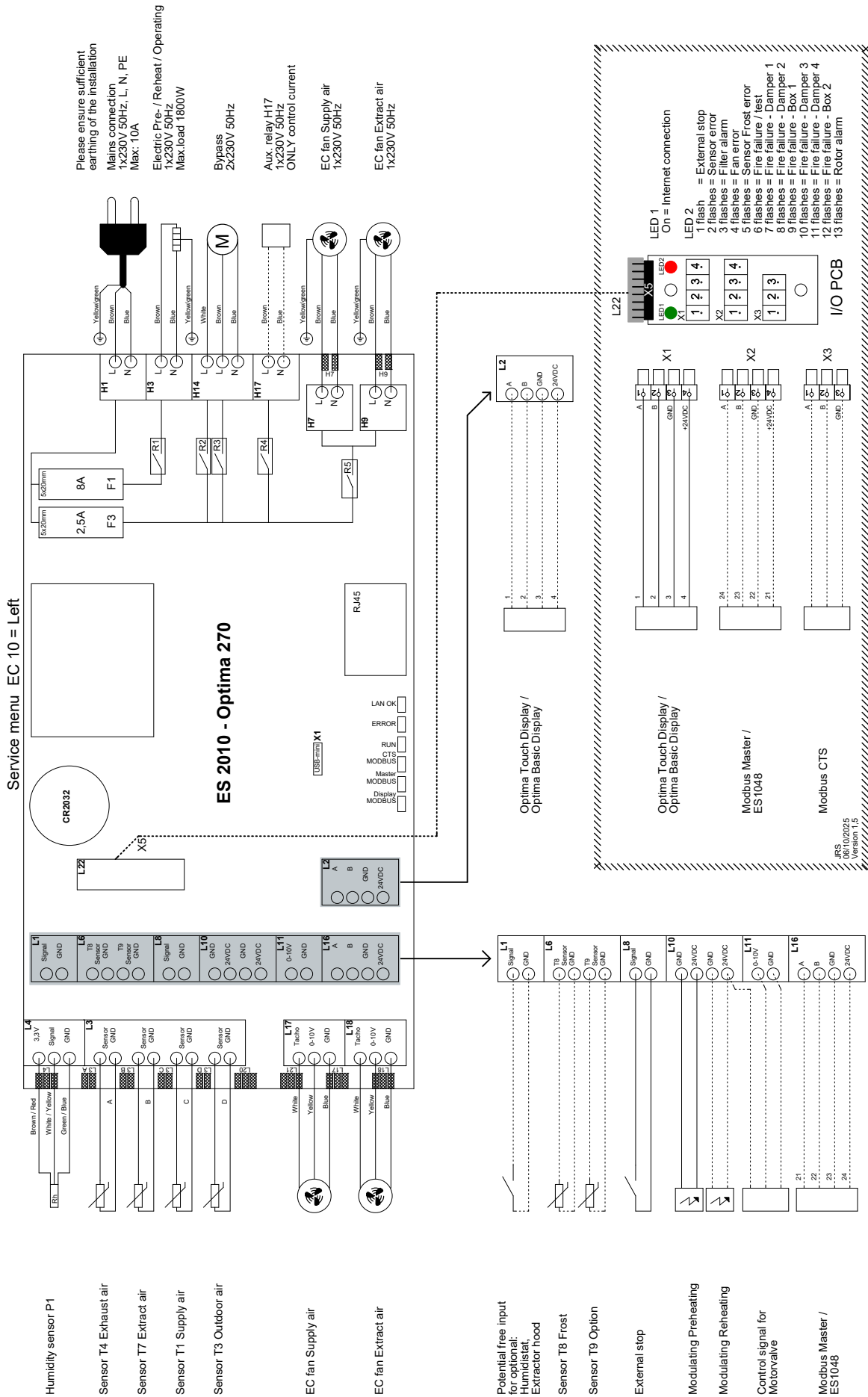

DECLARATION OF CONFORMITY

The declaration of conformity can be downloaded from www.genvex.com.

INSTRUCTIONS FOR DEINSTALLATION

For more information about dismantling components with a view to disposal and recycling
- see illustrations under "system maintenance"

THE AIR WE BREATHE

All
Genvex
systems are
rated with
energy label
A

As of 1 January 2025, Genvex has merged with our parent company METRO THERM into one company under the name METRO THERM A/S.

With the merger, both physical addresses will be retained: The head office and production for METRO THERM will remain in Helsingør, while administration and production for Genvex and KVM-Conheat will remain at the Haderslev address as a subdivision.

The three strong brands – METRO THERM, Genvex and KVM-Conheat – remain unchanged and will continue to be treated as independent brands under METRO THERM A/S.



Genvex – the original Danish ventilation system

Genvex is a true Danish original. We started producing ventilation systems in 1978 and are still the front runners when it comes to development and production of the most innovative and durable ventilation systems on the market.

Our units are installed in thousands of homes, providing clean, fresh air free from pollen, dust and harmful particles. They help lots of families with maintaining a healthy and comfortable indoor climate and prolong the longevity of the house itself. With very high heat recovery rates, a Genvex system lets you recover and reuse up to 95 % of the heat inside your home. As a result, our units provide a strong contribution to energy savings in both in family homes and in society as a whole.

