

ECO 400 XL



- Web interface and app monitoring.
- Well-suited for unheated rooms because of the high level of thermal insulation.
- Right/left version in the same unit.

ECO 400 XL is a ventilation unit for heat recovery with a highly efficient countercurrent exchanger, which has a temperature recovery rate of up to 96% and fans with energy-saving EC motors. ECO 400 XL is typically used in larger homes or small businesses where the focus is on comfort and low energy consumption.

ECO 400 XL stands apart from other ventilation units by being especially energy efficient and adapted to the strict requirements of NZEB energy class. The unit is especially well-suited for unheated rooms such as unused loft spaces because of the high level of thermal insulation. By default the unit is supplied with G4/Coarse filters on outdoor air intakes and on extract air (F7/ePM1 filter is supplied as an accessory).

ECO 400 XL can be equipped with a heat exchanger made from PET (plastic) or an enthalpy heat exchanger, where, in addition to heat exchange, it is also possible to recover the moisture from the exhaust air in the building.

The unit is supplied with an Optima 270 controller:

- Passive comfort cooling with fully automated bypass.
- Reduction of energy consumption with the aid of modulated humidity control and calendar program.
- Connection of electrical pre-heating or reheater, which adjusts the temperature as needed/wanted.
- Can be connected to a BMS unit via Modbus communication.
- Integrated RJ45 connection for cloud connection.
- Can be used without a display or with the option to connect either of two display types (Basic/Touch).
- Built-in data logging and the option of remote monitoring.

Please note that displays are sold separately.



Dimensional sketch

Dimensions
in mm

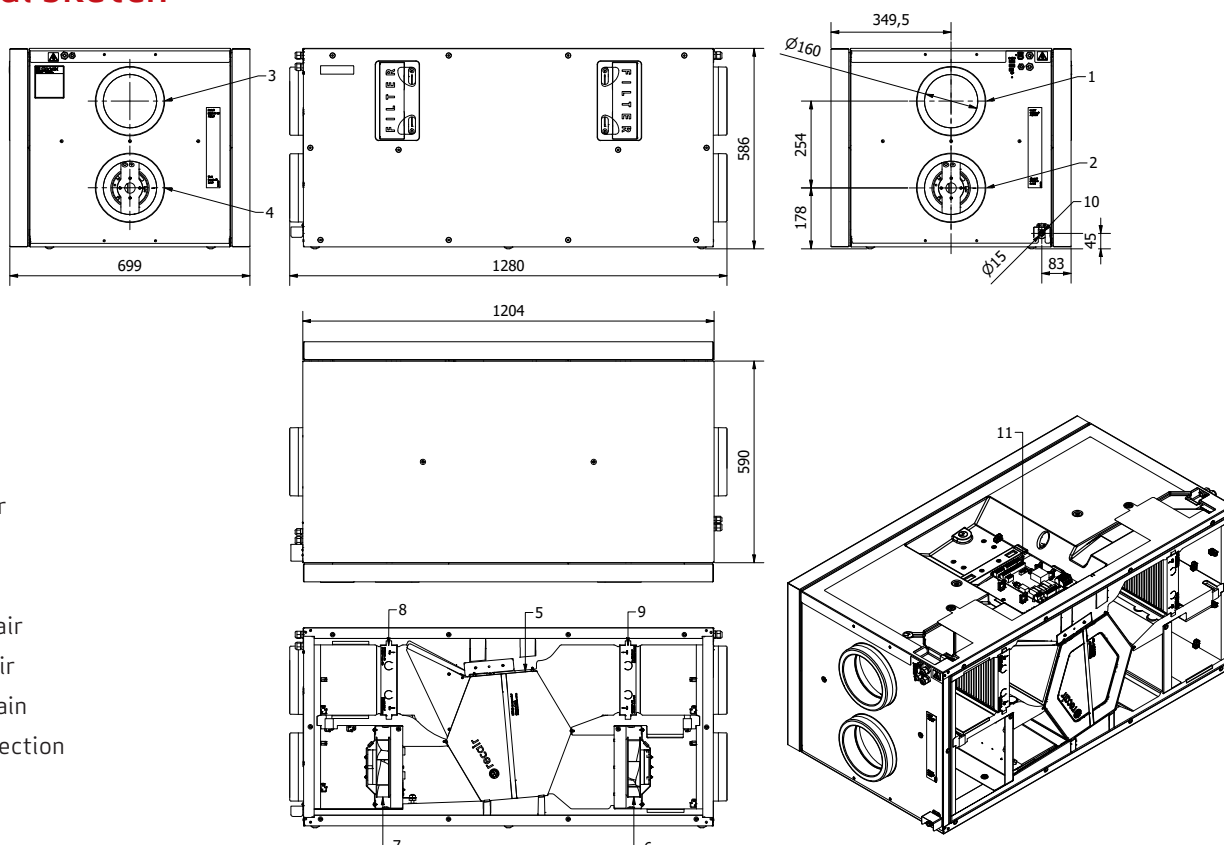

1. Outdoor air
2. Discharge
3. Extract air
4. Supply air
5. Heat exchanger
6. Supply air fan
7. Extract air fan
8. Filter outdoor air
9. Filter extract air
10. Condensate drain
11. Electrical connection

Technical data

ECO 400 XL

Electrical connection	1 x 230V +N +PE 10 A, 50 Hz
Fans	Ø180 mm backward-curved blades
Motor type	EC motor with integrated electronics
Insulation class for fan	B
Fan protection class	IP 44
Fan speed	4790 rpm
Power consumption (max. per motor)	170 W
Electricity consumption for fan	1,3 A
Dimensions (l x b x h) incl. connectors	1280x699x586 mm
Cabinet	Exterior: Galvanised sheet metal 0,9 mm Interior: EPS 50 mm
Duct connection	Exterior: Ø200/interior: Ø160
Front/back cover	Exterior: Galvanised sheet metal 0,9 mm Interior: EPS 50 mm/PE-packing
Mounting	Horizontal mounting on floor - right/left
Counterflow heat exchanger	Pet and enthalpy
Work area, countercurrent heat exchanger	-20 °C to +50 °C
Condensate drain	15 mm ABS
Filters	G4/Coarse (outdoor air/exhaust air) - F7/ePM1 (accessory)
Sound pressure level (Lp) at 1 m.	48 dB(A) @ 458 m³/h, 100 Pa
Weight	56 kg
Thermal insulation value	U=0,64 w/m²xK (klasse T2 iht. EN1886)
Energy class	A

Capacity

The capacity lines are based on an average value of supply air and exhaust air volumes in a unit. The graphs indicate the average external pressure available at a given air volume.

The capacity lines do not change with the use of an enthalpy heat exchanger rather than a PET heat exchanger.

SFP factors ECO 400 XL RC - measured in accordance with EN13141-7 (Coarse/ePM1)

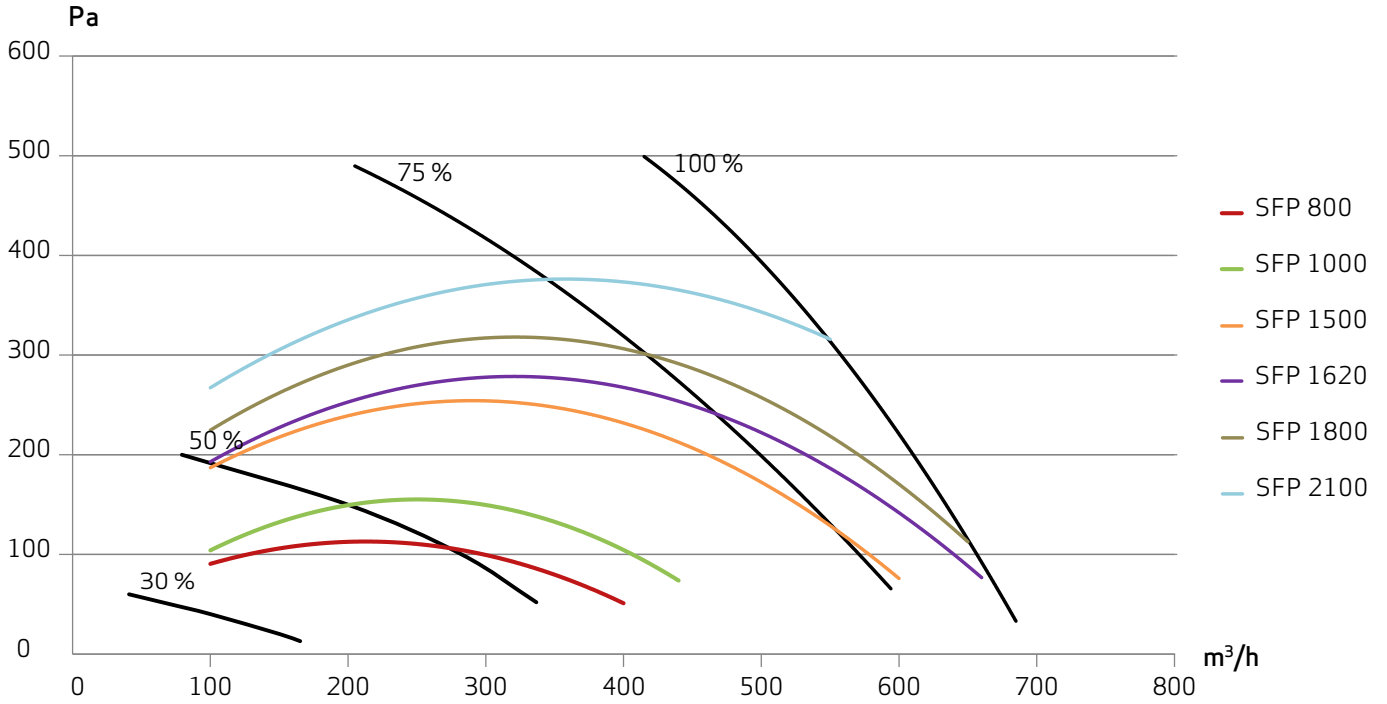

Power consumption

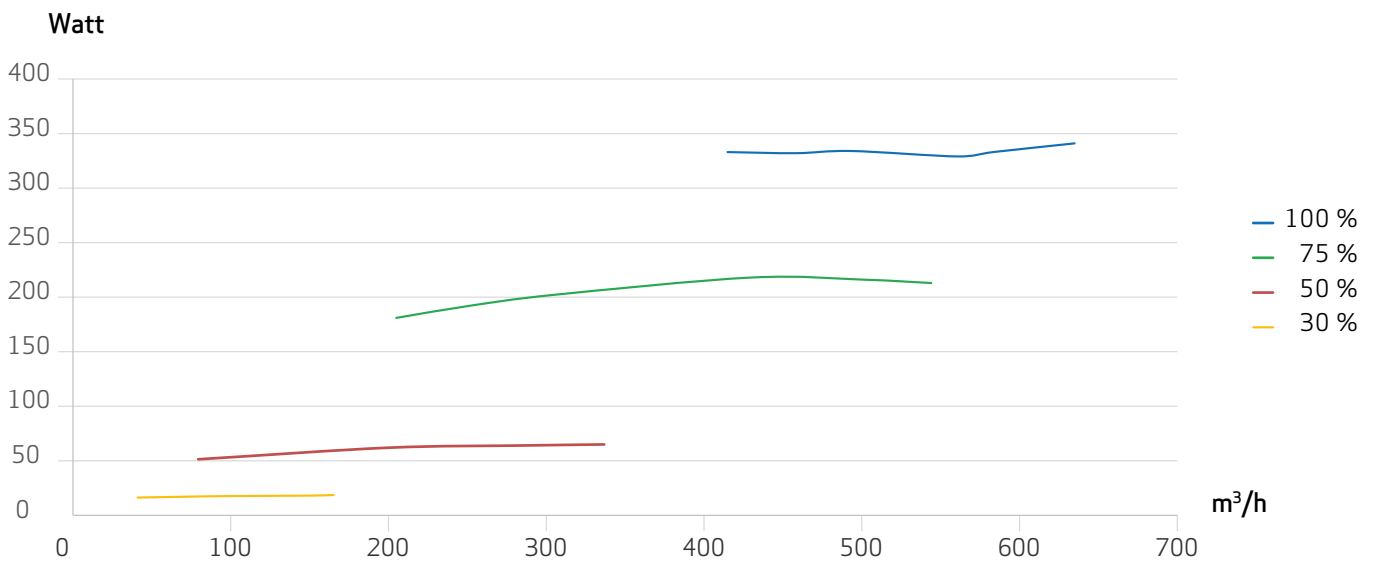

Temperature efficiency

“Dry” temperature efficiency in accordance with EN308 and balanced air flow on the outdoor air and extract air side. This does not account for any ice that may accumulate on the heat exchanger at low outdoor temperatures.

Temperature efficiency in accordance with EN308

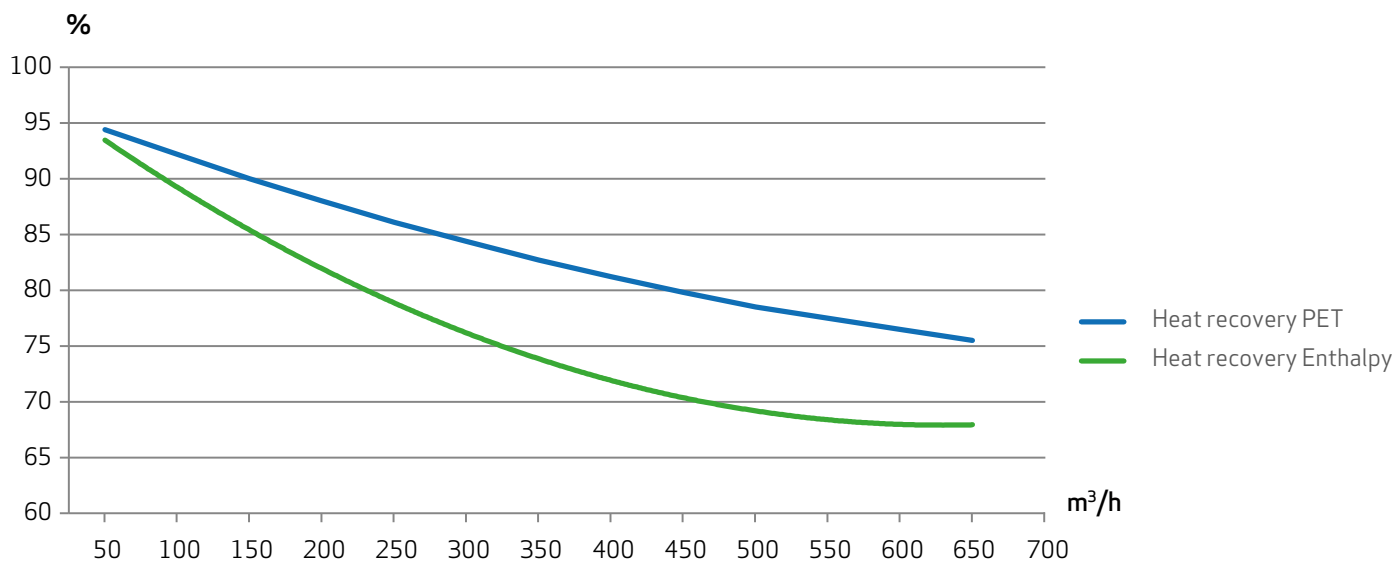

Sound data

Airflow (m³/h)	Pressure (Pa)			Frequency/Hz									
				63	125	250	500	1000	2000	4000	8000	Total	
126	70	Sound power level Lw dB(A)	Supply air	58,9	59,8	54,0	51,3	48,2	45,0	38,0	22,5	52,0	
			Exhaust	51,3	50,4	51,9	39,2	30,1	22,9	13,0	12,6	43,6	
			Outdoor	50,8	49,9	46,0	37,0	30,2	21,1	15,0	19,6	40,7	
			Extract	56,7	54,7	54,5	48,6	46,0	43,2	34,2	20,0	50,7	
	Sound pressure level Lp dB(A)@ 1 m.			Cabinet									35,3
	100	Sound power level Lw dB(A)	Supply air	61,3	60,0	55,6	50,9	49,2	46,5	37,6	24,3	53,2	
			Exhaust	48,8	49,6	49,3	39,1	31,2	24,4	17,5	13,5	43,4	
			Outdoor	50,5	50,8	52,6	41,9	34,1	23,9	14,1	12,7	45,3	
Extract			58,8	54,3	52,3	47,8	45,4	42,8	34,0	19,4	51,8		
Sound pressure level Lp dB(A)@ 1 m.			Cabinet									37,2	
162	70	Sound power level Lw dB(A)	Supply air	56,6	55,8	54,7	50,4	48,8	46,1	36,0	23,7	54,4	
			Exhaust	47,5	48,4	50,2	38,0	32,0	23,4	13,0	12,0	41,1	
			Outdoor	52,8	49,6	53,2	39,9	35,1	25,4	16,5	12,1	43,8	
			Extract	56,4	53,7	54,4	48,1	46,6	44,6	35,0	20,9	51,8	
	Sound pressure level Lp dB(A)@ 1 m.			Cabinet									35,7
	100	Sound power level Lw dB(A)	Supply air	60,9	59,8	58,4	52,1	49,4	48,2	39,4	26,4	55,3	
			Exhaust	48,9	50,5	52,0	40,3	33,6	26,3	14,6	12,6	44,2	
			Outdoor	51,9	47,1	48,9	39,9	33,2	23,8	15,0	12,3	43,8	
Extract			58,4	55,0	55,4	50,4	47,6	46,9	38,4	22,9	54,0		
Sound pressure level Lp dB(A)@ 1 m.			Cabinet									37,8	
216	70	Sound power level Lw dB(A)	Supply air	58,5	58,3	51,5	52,0	49,2	40,1	27,9	27,9	57,0	
			Exhaust	48,3	45,5	50,0	38,8	32,3	25,7	14,0	12,2	43,3	
			Outdoor	50,0	45,4	51,4	40,8	34,1	25,1	14,6	12,2	45,7	
			Extract	56,4	53,8	58,0	51,3	48,8	45,4	31,9	18,3	55,7	
	Sound pressure level Lp dB(A)@ 1 m.			Cabinet									37
	100	Sound power level Lw dB(A)	Supply air	61,2	58,8	66,7	55,5	53,2	51,4	43,2	30,4	61,5	
			Exhaust	48,5	47,4	53,9	41,5	35,7	29,8	17,1	12,2	46,3	
			Outdoor	54,5	54,7	56,6	43,8	39,3	30,5	18,3	12,3	48,5	
Extract			58,9	56,1	60,9	52,3	52,0	50,1	42,3	28,9	57,7		
Sound pressure level Lp dB(A)@ 1 m.			Cabinet									38,5	

Sound data

Airflow (m ³ /h)	Pressure (Pa)			Frequency/Hz									
				63	125	250	500	1000	2000	4000	8000	Total	
250	150	Sound power level Lw dB(A)	Supply air	57,2	58,5	60,5	54,2	51,1	50,1	40,2	26,4	58,0	
			Exhaust	50,0	47,1	51,1	39,2	35,5	30,6	24,9	18,8	45,5	
			Outdoor	54,2	49,1	51,1	41,9	37,0	29,3	20,4	13,4	44,9	
			Extract	57,4	55,1	64,8	51,4	50,1	50,7	39,3	27,7	56,8	
			Sound pressure level Lp dB(A)@ 1 m.	Cabinet									38,5
	200	Sound power level Lw dB(A)	Supply air	56,4	58,8	65,0	53,6	49,9	51,3	42,5	28,9	60,7	
			Exhaust	50,7	49,0	53,8	40,4	36,8	30,9	23,9	16,1	46,2	
			Outdoor	53,5	49,4	51,7	42,7	38,2	29,3	21,4	13,7	46,9	
Extract			58,8	55,3	59,5	52,9	50,2	50,6	41,8	27,7	58,1		
		Sound pressure level Lp dB(A)@ 1 m.	Cabinet									39,3	
300	150	Sound power level Lw dB(A)	Supply air	58,2	58,6	61,6	56,9	52,8	53,2	47,0	32,2	58,5	
			Exhaust	55,5	49,3	54,3	41,4	35,7	30,4	21,6	15,6	47,6	
			Outdoor	54	49,5	52,2	42,6	39,3	31,4	22,2	14,1	46,6	
			Extract	57,6	55,8	58,8	55,8	51,9	54,3	46,5	31,9	59,2	
			Sound pressure level Lp dB(A)@ 1 m.	Cabinet	49,6	45,6	45,0	35,4	34,2	30,5	24,8	16,9	39,7
	200	Sound power level Lw dB(A)	Supply air	59,8	59,2	63,0	60,6	53,6	53,2	46,6	32,5	62,0	
			Exhaust	49,0	49,0	53,0	43,7	38,0	34,1	26,5	16,8	49,4	
			Outdoor	54,3	50,2	55,4	46,7	40,2	31,2	23,2	15,2	49,9	
Extract			61,7	57,6	60,9	57,4	52,5	54,7	47,0	32,9	60,2		
		Sound pressure level Lp dB(A)@ 1 m.	Cabinet									42,9	
400	200	Sound power level Lw dB(A)	Supply air	63,7	60,1	63,3	64,0	57,1	58,1	52,5	38,6	66,6	
			Exhaust	59,7	52,2	55,5	50,4	42,5	36,2	27,8	20,4	52,6	
			Outdoor	52,9	52,1	57,5	54,7	47,5	36,4	29,0	17,9	53,1	
			Extract	64,3	59,2	62,4	63,0	60,0	59,6	55,7	41,9	65,3	
				Sound pressure level Lp dB(A)@ 1 m.	Cabinet								
458	100	Sound power level Lw dB(A)	Supply air	69,4	66,4	64,6	67,4	63,4	64,8	62,8	50,8	70,0	
			Exhaust	52,9	52,3	57,8	57,2	44,4	39,9	30,4	18,6	55,7	
			Outdoor	54,9	53	55,9	57,3	50,3	38,9	29,6	19,1	57,3	
			Extract	66,3	61,0	63,2	63,9	61,0	62,1	59,0	46,1	69,4	
				Sound pressure level Lp dB(A)@ 1 m.	Cabinet								
600	250	Sound power level Lw dB(A)	Supply air	71,4	68,6	67,8	72,8	65,4	65,7	61,8	51,7	73,5	
			Exhaust	58,0	56,7	59,9	54,8	48,2	43,0	35,7	27,0	56,3	
			Outdoor	58,8	57,3	56,9	61,8	55,8	45,4	37,2	29,2	61,5	
			Extract	72,2	67,6	67,0	68,6	66,1	66,6	63,4	54,1	72,7	
				Sound pressure level Lp dB(A)@ 1 m.	Cabinet								

Controller

ECO 400 XL comes with Optima 270 print circuit board. The Optima Design control panel, that connects to the Optima PCB, comes with a factory setting that makes it possible to put the system into operation without first needing to set the system's operational parameters.

The factory setting is only a basic setting that can be changed based on the customer's operational preferences and requirements for the building.

ECO 400 XL can be delivered with the following accessories:

- Genvex Automatic Fire Control.
- Water-based post-heating surface, incl. motor valve for installation in ventilation duct.
- Electric preheater and electric reheater plate for mounting in ventilation duct (electric preheater can be supplied pre-installed and integrated into the unit).
- Wireless sensor kit, which measures the level of CO₂ in individual rooms and control the MVHR unit accordingly.
- Condensate level switch.
- Optima Basic or Optima Touch control panel.

Control panel - Optima Touch



Speed

With this function, it is possible to set the fan speed in steps 0-1-2-3-4.



Extended operation

With this function, it is possible to set the timer for forced operation for between 0 and 9 hours.



Lock display

This function locks the display for 5 seconds. Typically used when wiping down the display



Main menu

With this function, it is possible to enter the main menu, where you will find the following sub-items: calendar, user menu, display, information menu and service menu.



Information

With this function, it is possible to get a good overview of the system's current operating condition, e.g. temperature, fan setting, relay status/functions, alarm, timer, etc.



Temperature

With this function, it is possible to set the desired temperature.

Contact us