

ECO 190 XL



- Compact installation dimensions – suitable for recessed ceilings
- High capacity and low energy consumption
- Integrated 100% bypass

The ECO 190 XL is a ventilation unit for heat recovery with a high-efficiency countercurrent exchanger with temperature efficiency of up to 94% and fans with energy-saving EC motors. The ECO 190 XL is used in homes or small businesses where the emphasis is on comfort and low energy consumption.

The ECO 190 XL is ideal for installation in buildings where space is limited and easy installation is required. The unit is compact and extremely service-friendly due to external connection options for displays and external Genvex equipment as well as rail pull-down of the control board for easy access to the terminal block. The ECO 190 XL can be supplied with either right-hand or left-hand configuration (defined by the extract air connection). As standard, the ECO 190 XL is supplied with G4/Coarse filters on the outdoor air intake and on the extract air (an M5/ePM10 or F7/ePM1 filter is supplied as an accessory).

The ECO 190 XL can be fitted with a PET (plastic) or aluminium heat exchanger. The PET heat exchanger is most suitable when heat recovery is the highest priority. To achieve the lowest possible electricity consumption, an aluminium heat exchanger is the right choice.

The system comes with an Optima 270 control:

- Passive comfort cooling with fully automatic 100% bypass.
- Reduced energy consumption by means of modulating humidity control and calendar programme.
- Connection of electric preheating or reheating surface, which adjusts the temperature according to need.
- Can be connected to a CTS system via Modbus communication.
- Integrated RJ45 connection on the control board for cloud connection of the system.
- Can be used without a display or with the option to connect either of two display types (Basic/Touch).
- Built-in data logging.

Please note that displays are sold separately.



Dimensional sketch

(the designations refer to a right-configured machine)

Dimensions in mm.

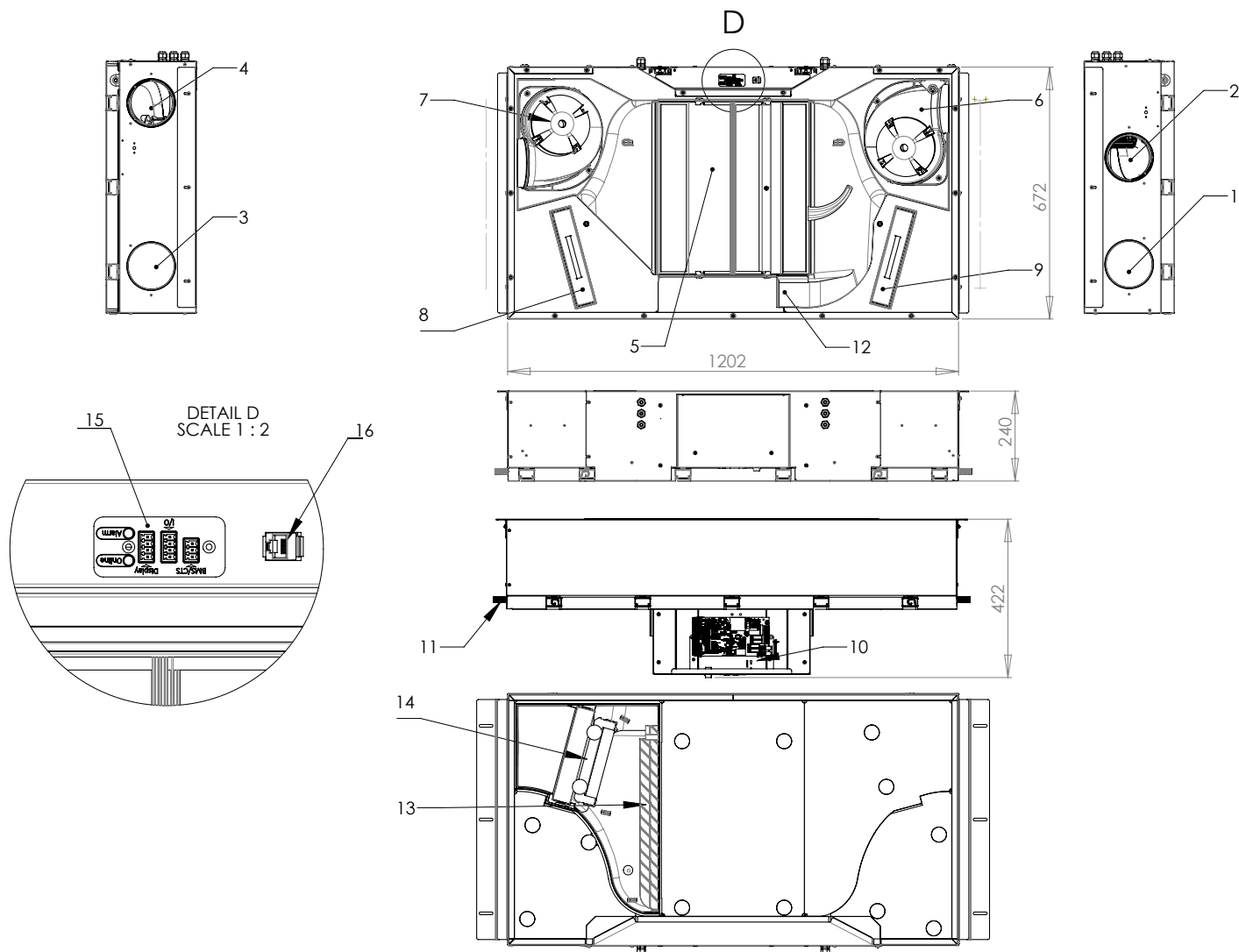

- | | |
|-----------------------------|--|
| 1. Outdoor air | 9. Extract air filter |
| 2. Exhaust air | 10. Electrical connection |
| 3. Extract air | 11. Condensate drain |
| 4. Supply air | 12. Bypass |
| 5. Countercurrent exchanger | 13. Bypass flap |
| 6. Supply air fan | 14. Preheater (option) |
| 7. Extract air fan | 15. IO Print (connection for display, external Genvex components and Modbus) |
| 8. Outdoor air filter | 16. RJ45 plug |

Technical data

ECO 190 XL	
Electrical connection	1 x 230 V +N +PE 10 A, 50 Hz
Fans	Ø133 mm backward-curved blades
Engine	EC motor with integrated electronics
Fan protection class	IP 54
Product protection class	IP X1B
Fan speed	5750 rpm
Recorded power (max. per motor)	85 W
Power consumption for fan	0.75 A
Dimensions (h x l x d) excl. connection pieces	241x1367x684 mm
Cabinet	Exterior: Galvanised steel sheet 0.9 mm Interior: Neoprene/EPS
Duct connection	Ø125 mm
Front	Exterior: Galvanised steel sheet, 0.7 mm powder coated Interior: Neoprene/EPS
Ceiling mounting	Ceiling mounting plate with 6.5 mm holes
Countercurrent heat exchanger	Aluminium, PET or enthalpy
Working range, countercurrent exchanger	-20°C to +50°C
Condensate drain	15 mm ABS
Filters	G4/Coarse (outdoor air and discharge) F7/ePM1 (accessory)
Sound pressure level (L _w) at 1 m	44.6 dB (A) @ 162 m ³ /h, 70 Pa
Weight	25 kg (31 kg with base plate)
Energy class	A

Capacity

The capacity lines are based on an average value of supply and discharge air volume in a unit. The curves indicate the average external pressure available at a given air volume. The SEL curves are reduced by 10 Pa using PET exchangers. Power consumption for control is not included in the SEL value (approx. 6 watts).

SEL factors ECO 190 XL - measured according to EN13141-7 (G4/G4: ALU)

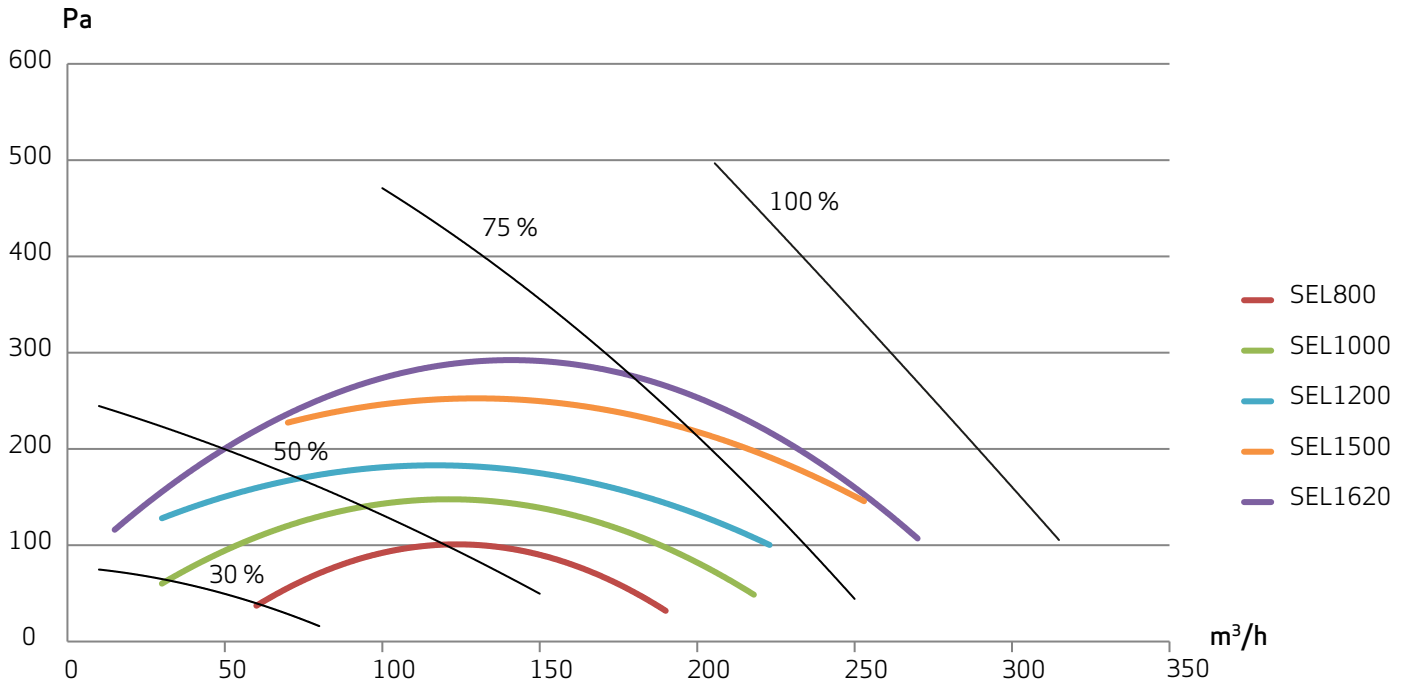

Temperature efficiency

“Dry” temperature efficiency according to EN308 and at the same air flow on the outdoor air and discharge air side. No account has been taken of any icing on the heat exchanger at low outdoor temperatures.

Temperature efficiency - measured according to EN308

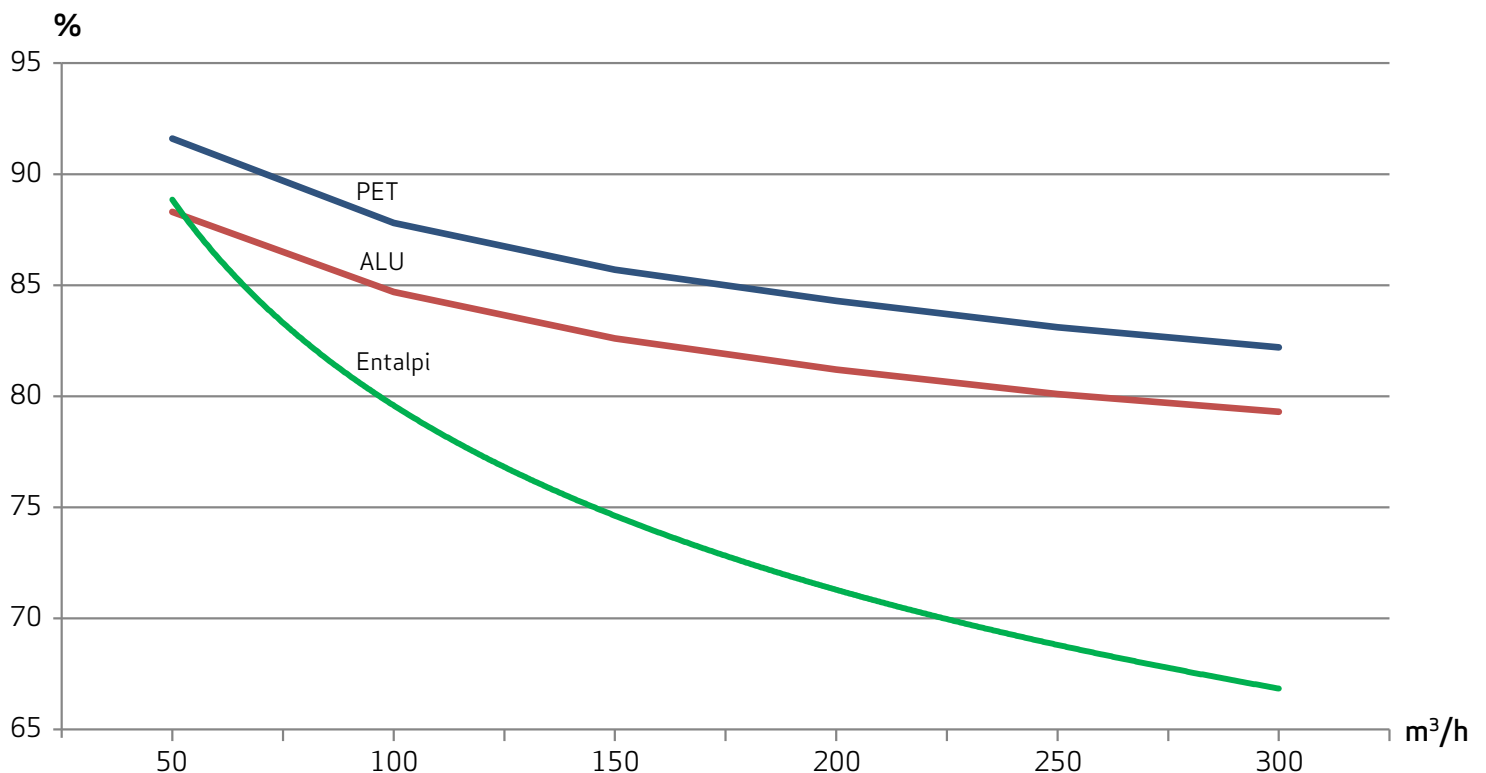

Noise data - ECO 190 XL

Airflow (m ³ /h)*	Pressure (Pa)			Frequency/Hz								
				63	125	250	500	1000	2000	4000	8000	Total
126	70	Sound Power Level Lw dB(A)	Supply air	19,8	24,4	37,1	39,2	31,9	24,9	23,1	18,5	44,9
			Exhaust air	19,0	26,4	28,1	28,5	27,0	24,2	20,2	16,6	35,4
			Outdoor air	16,6	19,8	26,7	25,4	24,7	22,6	19,6	16,8	32,2
			Extract air	20,5	29,9	40,9	42,7	39,6	33,4	30,8	25,5	47,7
		Sound Pressure Level Lp dB(A)@ 1 m. Cabinet	13,8	23,2	29,3	30,8	29,4	30,0	24,0	20,0	40,8	
	100	Sound Power Level Lw dB(A)	Supply air	22,4	30,1	41,2	42,2	33,8	27,1	24,4	17,4	45,5
			Exhaust air	20,7	27,6	28,9	30,0	27,7	24,8	20,7	16,7	37,7
			Outdoor air	17,4	20,9	28,9	27,0	26,5	22,7	19,2	16,3	33,6
			Extract air	20,7	31,2	42,1	43,4	40,4	34,0	30,4	23,9	48,6
		Sound Pressure Level Lp dB(A)@ 1 m. Cabinet	14,2	23,6	30,5	32,1	30,4	30,1	23,4	18,5	42,2	
162	70	Sound Power Level Lw dB(A)	Supply air	20,9	28,1	40,2	45,1	35,6	32,3	29,9	23,6	47,4
			Exhaust air	21,0	27,6	28,6	30,9	27,4	27,5	23,4	19,2	36,6
			Outdoor air	15,4	20,3	26,2	27,1	25,6	24,8	22,3	18,1	33,2
			Extract air	23,2	30,4	41,5	46,0	41,9	38,1	36,7	32,6	50,2
		Sound Pressure Level Lp dB(A)@ 1 m. Cabinet	13,5	23,0	30,6	33,8	32,1	35,4	29,1	25,3	44,3	
	100	Sound Power Level Lw dB(A)	Supply air	22,1	30,2	41,2	46,2	38,1	33,3	30,8	25,3	48,2
			Exhaust air	20,5	26,6	28,7	31,8	27,7	27,2	23,2	19,1	37,3
			Outdoor air	21,4	20,6	27,6	29,0	27,9	25,8	22,9	18,9	35,0
			Extract air	23,5	31,3	42,1	46,7	43,7	38,3	36,5	33,9	51,1
		Sound Pressure Level Lp dB(A)@ 1 m. Cabinet	12,5	25,7	30,5	37,8	33,9	35,8	29,9	25,4	45,5	
216	70	Sound Power Level Lw dB(A)	Supply air	23,0	29,8	40,8	48,9	38,6	37,4	37,5	30,6	50,6
			Exhaust air	20,5	25,4	31,1	34,8	33,4	31,6	28,6	22,6	40,4
			Outdoor air	19,7	21,1	27,7	31,5	29,9	29,4	27,6	21,5	37,0
			Extract air	25,2	33,5	43,8	49,5	45,9	43,0	43,5	39,9	54,3
		Sound Pressure Level Lp dB(A)@ 1 m. Cabinet	12,4	25,2	31,7	40,2	37,9	42,2	35,8	31,2	49,4	
	100	Sound Power Level Lw dB(A)	Supply air	26,9	31,4	41,4	48,9	41,1	38,9	38,3	31,8	50,9
			Exhaust air	21,9	27,1	31,5	38,0	35,7	32,4	29,4	24,2	42,6
			Outdoor air	20,1	21,5	30,1	32,2	32,3	29,6	28,0	23,1	38,4
			Extract air	27,2	33,8	44,5	51,9	46,9	44,4	43,8	40,4	55,7
		Sound Pressure Level Lp dB(A)@ 1 m. Cabinet	14,5	26,5	32,4	39,8	37,3	40,7	33,3	32,7	49,8	
250	150	Sound Power Level Lw dB(A)	Supply air	27,8	34,4	44,3	50,8	43,8	41,7	41,4	36,8	53,8
			Exhaust air	23,3	27,3	33,4	40,3	37,6	35,4	32,4	25,9	44,6
			Outdoor air	21,0	23,9	32,4	36,3	37,4	35,2	34,6	28,1	42,6
			Extract air	31,1	36,6	46,5	52,6	50,4	47,5	47,1	43,7	57,8
		Sound Pressure Level Lp dB(A)@ 1 m. Cabinet	19,9	28,8	35,0	41,8	41,8	44,0	42,3	37,6	51,9	
	200	Sound Power Level Lw dB(A)	Supply air	31,9	36,3	45,2	51,3	45,4	43,9	42,6	37,1	54,5
			Exhaust air	23,6	29,5	34,8	41,7	38,4	36,6	33,2	26,1	45,9
			Outdoor air	18,4	24,0	34,3	37,3	38,9	34,6	32,4	21,0	43,4
			Extract air	31,6	37,0	46,4	54,0	51,5	47,8	47,5	44,1	58,9
		Sound Pressure Level Lp dB(A)@ 1 m. Cabinet	20,6	28,7	35,7	42,1	41,4	43,5	40,0	37,1	53,0	

Automatic control

The ECO 190 XL comes with the Optima 270 automatic control. The Optima control comes with a factory setting, which makes it possible to put the system into operation without first having to configure the system's operating menu.

The factory setting is just a basic setting that can be changed to match your operational desires and requirements for your home.

THE ECO 190 XL can be supplied with the following accessories:

- Genvex mixing loop automatic control for weather compensation of district heating and central heating systems
- Genvex automatic fire control
- Water-based reheating surface, incl. motor valve, for mounting in ventilation duct
- Electric preheating surface and electric reheating surface for installation in ventilation duct
- Base plate (for flush installation in recessed ceiling, allowing optimal accessibility)
- Condensation level switch (safety switch), possibly in combination with condensate pump
- Optima Basic or Optima Touch control panel.
- Integrated preheating surface

Control panel - Optima Touch



Speed

With this function, it is possible to set the fan speed in steps 0-1-2-3-4.



Extended operation

With this function, it is possible to set the timer for forced operation for between 0 and 9 hours.



Lock display

This function locks the display for 5 seconds. Typically used when wiping the display.



Main menu

With this function, it is possible to enter the main menu, where you will find the following sub-items: calendar, user menu, display, information menu and service menu.



Information

With this function, it is possible to get a good overview of the system's current operating condition, e.g. temperature, fan setting, relay status/functions, alarm, timer, etc.



Temperature

With this function, it is possible to set the desired temperature.

Contact us